

GLORYSTAR

GLORYSTAR

LASER TECHNOLOGY BUILDS A BETTER WORLD

Dongguan HEADQUARTERS

Address:
No. 47, Jingyi Road,
Niushan Industrial Park,
Dongguan, Guangdong, China.

Shenzhen

Address:
Building 2, Huike Industrial Park,
Shilong Community, Bao'an District,
Shenzhen, China.

 www.glorylaser.com

Henan

Address:
GLORYSTAR Laser Intelligent Equipment Co., Ltd.,
Yicheng District, Zhumadian City,
Henan, China.

V202508

**Adherence to 339 Quality Inspection Standards
Your Most Trusted One-Stop Expert for
Mid to High-End Laser Application Solutions**

APPLICATION SOLUTIONS MANUAL





**ADHERENCE TO 339
QUALITY INSPECTION STANDARDS**
YOUR MOST TRUSTED ONE-STOP EXPERT FOR
MID TO HIGH-END LASER APPLICATION SOLUTIONS



**339 QUALITY INSPECTION
STANDARDS**

144+
Material Inspection Standards

70+
Assembly Process
Inspection Standards

125+
Whole-Machine Precision
Inspection Standards

Upholding Every Line of Defense
for High-Quality Delivery



**5 STAR
THOUGHTFUL SERVICE**

Online 24/7 after-sales
technical support

On-site support
within 24 hours

Dedicated service channel
with a one-on-one service team

Attentive product manager providing
remote installation guidance

Professional technical training



**MID-TO-HIGH-END
LASER APPLICATION SOLUTIONS**

Cutting, welding, bending
and automation solutions
for metals includes sheets, tubes
and irregular materials,
safeguarding your modern processing needs

Serving 100,000+
mid-to-high-end clients worldwide



INDUSTRY EXPERTISE

20+
Years in Laser Intelligent Equipment

200+
Expert Advisory Team



ABOUT US

Glorystar Laser specializes in laser application solutions, including laser cutting, laser welding, laser cleaning, CNC bending, and automated production lines. The company has been recognized as "National High-Tech Enterprise," "Specialized & Sophisticated 'Little Giant' Enterprise," "Guangdong Intellectual Property Demonstration Enterprise," and "Guangdong Famous Brand Product."

With a professional R&D and technical support team, Glorystar Laser holds over 400 independent intellectual property rights and has established the "Laser Application Research Institute" and "Intelligent Manufacturing Research Institute," mastering core intelligent manufacturing technologies. Committed to mid-to-high-end quality, Glorystar Laser enforces strict 339-step inspection procedures and maintains a comprehensive quality traceability management system. All products are certified by ISO 9001 Quality Management System, ISO 14001 Environmental Management System, and other international authoritative certifications.

Offering 24/7 worry-free "online + offline" after-sales service, Glorystar Laser delivers premium products and services globally, contributing to societal progress and fulfilling its mission: "Laser Technology Builds a Better World."



5 KEY INTERNATIONAL REGIONS Americas, Oceania, Europe, Asia, Middle & East Africa

To become the world's No.1 provider of laser application solutions

VISION

To pursue both material and spiritual well-being for all employees continuously create value for customers, and contribute to the advancement of human society, Laser technology builds a better world

MISSION

Professionalism, Efficiency, Integrity, Responsibility, Innovation, and Dedication

CORE VALUES



SPECIALIZING IN LASER CUTTING, WELDING, CNC BENDING, AUTOMATED PRODUCTION SOLUTIONS



Total Facility Area

200000m²

Global Service Centers

100+

Worldwide Customers Served

100000+

Service Engineers

200+

Technical Patents & Intellectual Property

400+

METAL LASER CUTTING INDUSTRY SOLUTIONS



Steel Structure Engineering



Shipbuilding



Heavy Machinery

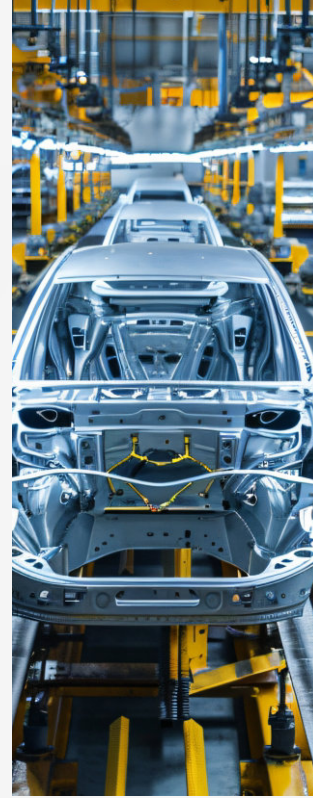

Automotive Manufacturing



Sheet Metal Processing



Furniture & Home Appliances



Building Materials & Hardware

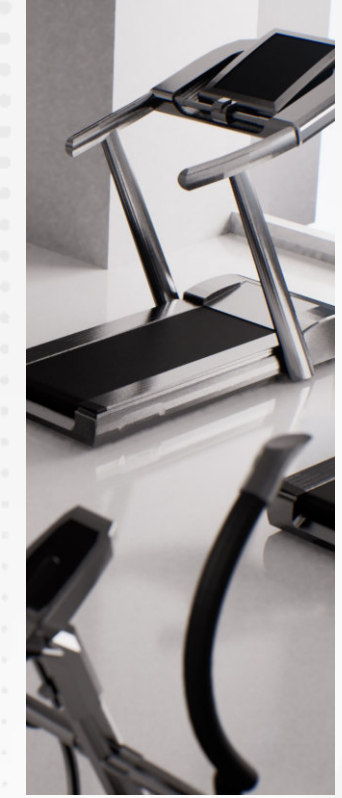

Fitness Equipment

PRODUCT SERIES



SHEET LASER CUTTING MACHINE



TUBE LASER CUTTING MACHINE



BENDING MACHINE



AUTOMATION EQUIPMENT

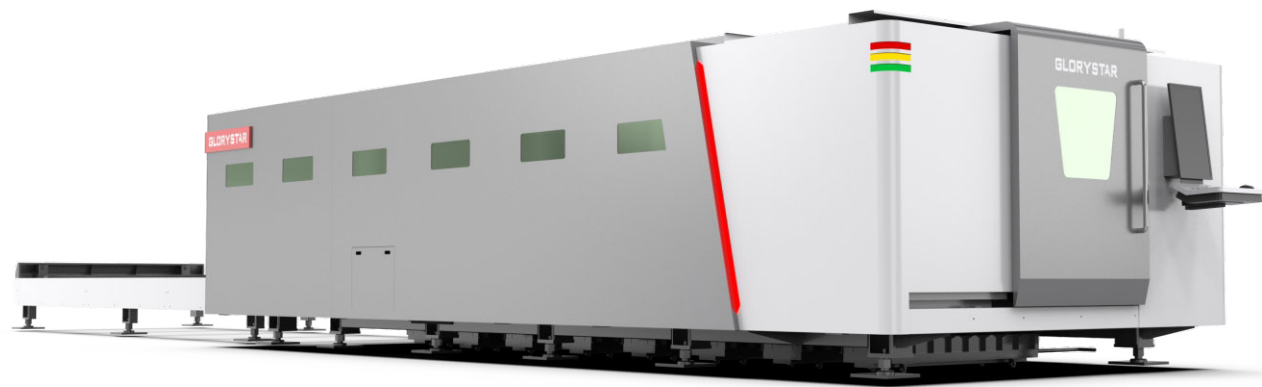

NS-CE Series **HEAT-RESISTANT** **DEFORMATION-RESISTANT**

ULTRA-HIGH POWER
FIBER LASER METAL SHEET CUTTING MACHINE

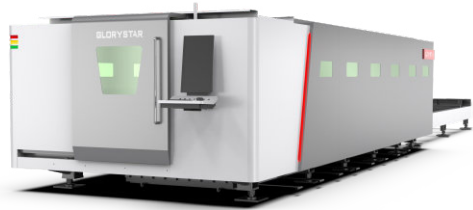

TECHNICAL SPECIFICATIONS

Model	NS-4020CE	NS-6020CE	NS-6025CE	NS-8025CE	NS-12025CE
Max. material width (mm)	4000×2000 13×7ft	6000×2000 20×7ft	6000×2500 20×8ft	8000×2500 26×8ft	12000×2500 39×8ft
X axis travel (mm)	2030 / 6.7ft	2030 / 6.7ft	2530 / 8.3ft	2530 / 8.3ft	2530 / 8.3ft
Y axis travel (mm)	4050 / 13.3ft	6050 / 19.9ft	6050 / 19.9ft	8050 / 26.4ft	12050 / 39.5ft
Z axis travel (mm)	460 / 1.5ft	460 / 1.5ft	460 / 1.5ft	460 / 1.5ft	460 / 1.5ft
X/Y positioning accuracy	≤0.03mm/m / 0.00118in/39.4in				
X/Y repeat positioning accuracy	≤±0.02mm / 0.00079in				
Max. synthetic positioning speed	190m/min / 624.5ft/min				
Max. acceleration	3.5G	3.5G	3.0G	2.8G	2.8G
Slit width	0.1mm-0.5mm / 0.0039in-0.0197in				
Incision roughness	Ra3.2um-Ra25.4um / Ra0.000126-Ra0.001in				
Max. cutting thickness range	Refer to the following process parameter table				
Min. setting unit	0.001mm / 0.00039in				
Floor area of machine tool (mm)	12000×5500 39.4×18ft	16000×5500 52.5×18ft	16000×6000 52.5×19.7ft	22000×6000 72.2×19.7ft	30000×6000 98.4×19.7ft
Host volume (mm)	11300×3800×2500 37.1×12.5×8.2ft	15300×3800×2500 50.2×12.5×8.2ft	15300×4200×2500 50.2×13.8×8.2ft	21300×4400×2500 69.9×14.4×8.2ft	28200×4400×2500 93×14.4×8.2ft
CNC system	BOCHU				
Monitor	27" LCD				
Transfer method	Rack and pinion dual drive				
Max. load-bearing capacity of worktable (tons)	10.1 / 22250lbs	15.1 / 33225lbs	18.9 / 41668lbs	25.2 / 55557lbs	37.7 / 83049lbs
Total installed power consumption	12000W			100KVA	
	20000W			150KVA	
	30000W			200KVA	
	40000W			300KVA	
Power requirements	AC380V , 50Hz ; 3P+N+PE				
Total power protection level	IP51				
Instruction	The products provided by the company are optimized and upgraded according to the research and development process. This technical description is suitable for most models. The products purchased by customers may differ from the specified configuration. This manual does not confirm the contract delivery of machinery and equipment.				

PATENTED DUAL-BED DESIGN FOR PRECISION AND STABILITY

Features a patented dual-bed structure that fundamentally eliminates precision losses caused by heavy loads and thermal deformation. Bending rigidity is increased by over 50%, effectively solving stability challenges during medium-to-thick plate processing, ensuring sustained precision and reliability over prolonged operation.



LOW-CENTER-OF-GRAVITY, HIGH-RIGIDITY BEAM

The low-center-of-gravity beam with a large cross-sectional design achieves an ideal balance between lightweight construction and exceptional rigidity, greatly enhancing acceleration, deformation resistance, and sustained accuracy, keeping the equipment in optimal working condition.

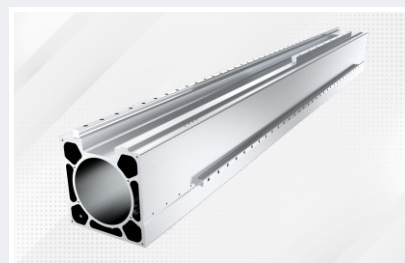

EXTRA-THICK PLATE PROCESSING FOR EXTENDED CAPABILITIES

Supports full-format exchange cutting of extra-thick plates up to 100 mm, offering robust performance for heavy-duty material processing, fully meeting diverse complex application demands.

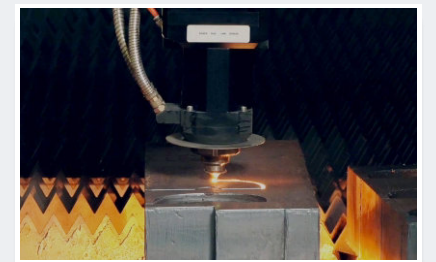

FULL SERVO CONTROL FOR PRECISE POSITIONING

The machine's fully servo-controlled system achieves millimeter-level table movement accuracy, effectively improving positioning precision and traction force, reducing fault rates, and ensuring efficient and stable production.

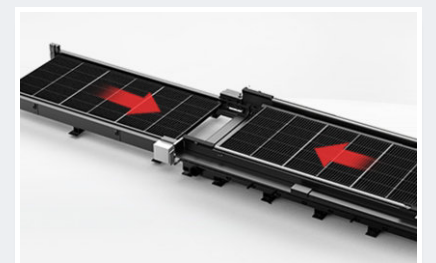



GS-CE Series **HIGH-SPEED** **ECO-FRIENDLY**

**COVER EXCHANGED FIBER
LASER METAL SHEET CUTTING MACHINE**

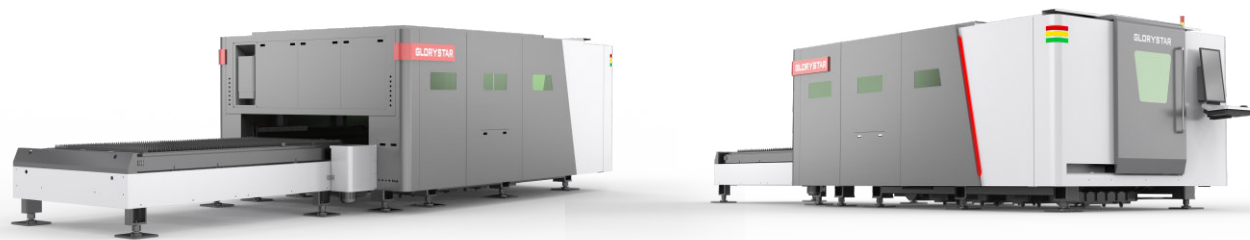

TECHNICAL SPECIFICATIONS

Model	GS-3015CE	GS-4015CE	GS-4020CE	GS-6015CE	GS-6020CE	GS-6025CE
Max. material width (mm)	3000×1500 5×10ft	4000×1500 5×13ft	4000×2000 7×13ft	6000×1500 5×20ft	6000×2000 7×20ft	6000×2500 8×20ft
X axis travel (mm)	1530 / 5.1ft	1530 / 5.1ft	2030 / 6.8ft	1530 / 5.1ft	2030 / 6.8ft	2530 / 8.4ft
Y axis travel (mm)	3030 / 10ft	4030 / 13.3ft	4030 / 13.3ft	6030 / 19.9ft	6030 / 19.9ft	6030 / 19.9ft
Z axis travel (mm)	290 / 1ft	290 / 1ft	290 / 1ft	290 / 1ft	290 / 1ft	290 / 1ft
X/Y positioning accuracy	≤0.03mm/m / 0.00118in/39.4in					
X/Y repeat positioning accuracy	≤±0.02mm / 0.00079in					
Max. synthetic positioning speed	170m/min / 557.8ft/min					
Max. acceleration	2.8G	2.8G	2.5G	2.8G	2.5G	2.0G
Slit width	0.1mm-0.5mm / 0.0039in-0.0197in					
Incision roughness	Ra3.2um-Ra25.4um / Ra0.000126-Ra0.001in					
Max. cutting thickness range	Refer to the following process parameter table					
Min. setting unit	0.001mm / 0.00003937in					
Floor area of machine tool (mm)	10100×4000 33.1×13.2ft	12200×4000 40.2×13.2ft	12200×4500 40.2×14.8ft	17560×4000 57.6×13.2ft	17560×4500 57.6×14.8ft	17560×5000 57.6×16.4ft
Host volume (mm)	9100×3120×2200 29.6×10.3×7.3ft	11200×3120×2200 36.1×10.3×7.3ft	11200×3620×2200 36.1×11.9×7.3ft	16560×3120×2200 54.3×10.3×7.3ft	16560×3620×2200 54.3×11.9×7.3ft	16560×4120×2200 54.3×13.6×7.3ft
CNC system	BOCHU					
Monitor	27" LCD					
Transfer method	Rack and pinion dual drive					
Max. load-bearing capacity of worktable (tons)	2.2 / 4850lbs	2.8 / 6173lbs	3.8 / 8377lbs	4.3 / 9481lbs	5.7 / 12566lbs	7.1 / 15653lbs
Total installed power consumption	3000W			27KVA		
	6000W			42KVA		
	12000W			100KVA		
Power requirements	AC380V , 50Hz ; 3P+N+PE					
Total power protection level	IP51					
Instruction	The products provided by the company are optimized and upgraded according to the research and development process. This technical description is suitable for most models. The products purchased by customers may differ from the specified configuration. This manual does not confirm the contract delivery of machinery and equipment.					

RAPID START-STOP WITH MILLISECOND-LEVEL ACCELERATION

This laser cutting machine delivers explosive, millisecond-level acceleration. Its patented hollow bed structure prevents heavy load risks and thermal deformation, boosting bending rigidity by over 50% and ensuring precise, stable processing of medium-to-thick plates.



LOW-CENTER-OF-GRAVITY, HIGH-RIGIDITY ALUMINUM ALLOY BEAM

Equipped with a 250×250mm aerospace-grade aluminum alloy beam featuring a low-center-of-gravity and large cross-sectional design, it combines lightweight strength with exceptional rigidity, significantly enhancing acceleration, deformation resistance, and precision maintenance—providing robust structural support for every cut.



ADVANCED INTELLIGENT DUST REMOVAL SYSTEM

Equipped with an intelligent dust removal system featuring 8 to 30 automated high-suction zones for efficient smoke extraction. Standard safety features include anti-collision beam protection via light curtains, multi-scenario adaptability, automatic grease lubrication, and an MCA-regulated electrical cabinet, ensuring reliable and efficient operation.



DUAL-STATION HIGH-SPEED EXCHANGE WORKTABLES

The dual-station design enables independent loading/unloading and cutting processes, rapidly switching between tasks to dramatically boost production efficiency and fulfill high-speed continuous processing demands.

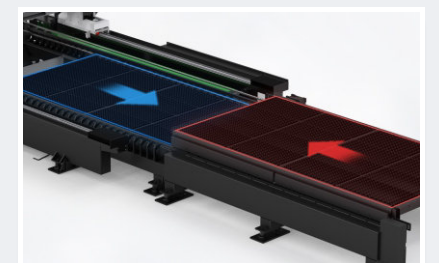

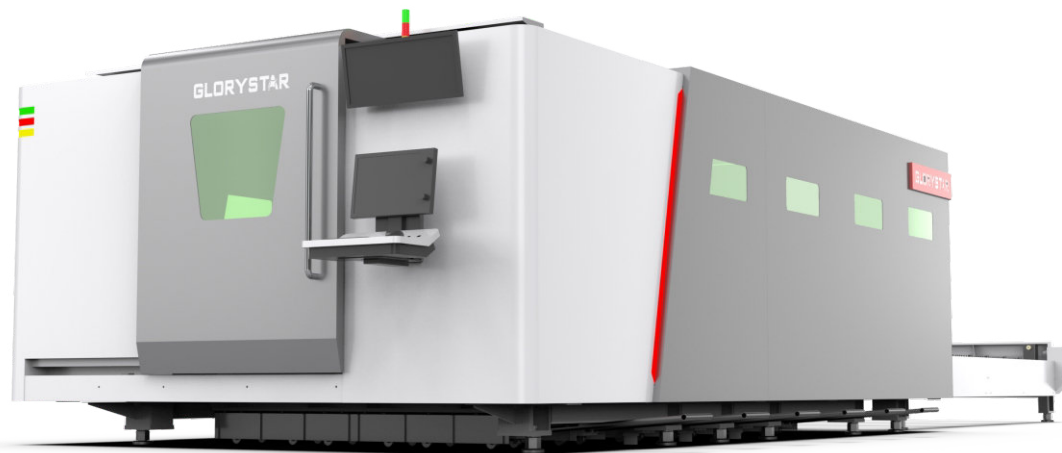

GS-CE Pro Series

HIGH PAYLOAD

DEFORMATION-RESISTANT

COVER EXCHANGED FIBER LASER METAL SHEET CUTTING MACHINE



TECHNICAL SPECIFICATIONS

Model	GS-3015CE Pro	GS-4020CE Pro	GS-6020CE Pro	GS-6025CE Pro	GS-8025CE Pro	GS-12025CE Pro
Max. material width (mm)	3000×1500 10×5ft	4000×2000 13×7ft	6000×2000 20×5ft	6000×2500 20×8ft	8000×2500 26×8ft	12000×2500 40×8ft
X axis travel (mm)	1530 / 5.1ft	2030 / 6.7ft	2030 / 6.7ft	2530 / 8.3ft	2530 / 8.3ft	2530 / 8.3ft
Y axis travel (mm)	3030 / 9.9ft	4030 / 13.2ft	6030 / 19.8ft	6030 / 19.8ft	8030 / 26.3ft	12030 / 39.5ft
Z axis travel (mm)	430 / 1.4ft	270 / 0.9ft	270 / 0.9ft	430 / 1.4ft	430 / 1.4ft	430 / 1.4ft
X/Y positioning accuracy	≤0.03mm/m / 0.00118in/39.4in					
X/Y repeat positioning accuracy	≤±0.02mm / 0.00079in					
Max. synthetic positioning speed	190m/min / 624.5ft/min					
Max. acceleration	4.0G	3.5G	3.5G	3G	2.8G	2.8G
Slit width	0.1mm-0.5mm / 0.0039in-0.0197in					
Incision roughness	Ra3.2um-Ra25.4um / Ra0.000126-Ra0.001in					
Max. cutting thickness range	Refer to the following process parameter table					
Min. setting unit	0.001mm / 0.00003937in					
Floor area of machine tool (mm)	9240×4000 30.3×13.2ft	12200×4500 40.1×14.8ft	16560×4500 54.4×14.8ft	16560×5000 54.4×16.4ft	20850×5000 68.4×16.4ft	29150×5000 95.7×16.4ft
Host volume (mm)	9140×3030×2640 30×10×8.7ft	11200×3620×2200 36.8×11.9×7.3ft	15560×3620×2200 51.1×11.9×7.3ft	15560×4120×2600 51.1×13.5×8.6ft	19850×4120×2600 65.2×13.6×8.6ft	28150×4200×2600 92.4×13.8×8.6ft
CNC system	BOCHU					
Monitor	27" LCD					
Transfer method	Rack and pinion dual drive					
Max. load-bearing capacity of worktable (tons)	4.3 / 9481lbs	6.2 / 13669bs	9.3 / 20403lbs	14.2 / 31306lbs	18.9 / 41668lbs	28.3 / 62391lbs
Total installed power consumption	12000W			100KVA		
	20000W			150KVA		
	30000W			200KVA		
	40000W			300KVA		
Power requirements	AC380V , 50Hz ; 3P+N+PE					
Total power protection level	IP51					
Instruction	The products provided by the company are optimized and upgraded according to the research and development process. This technical description is suitable for most models. The products purchased by customers may differ from the specified configuration. This manual does not confirm the contract delivery of machinery and equipment.					

DUAL GUARANTEE OF STABILITY AND PRECISION

An industry-first dual-support design separates the transmission system from the sheet metal support system, effectively preventing bed deformation caused by heavy loads. This innovative structure increases bending resistance by over 50%, delivering enhanced stability and solving the challenges of processing medium and thick plates with consistent precision.



ADVANCED INTELLIGENT DUST REMOVAL SYSTEM

Equipped with an intelligent dust removal system featuring 8 to 30 automated high-suction zones for efficient smoke extraction. Standard safety features include anti-collision beam protection via light curtains, multi-scenario adaptability, automatic grease lubrication, and an MCA-regulated electrical cabinet, ensuring reliable and efficient operation.

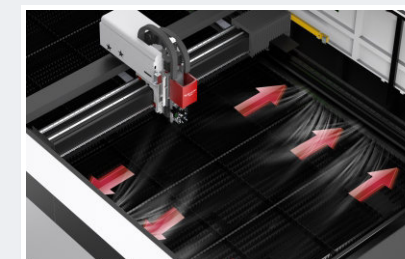

LOW-CENTER-OF-GRAVITY, HIGH-RIGIDITY ALUMINUM ALLOY BEAM

Equipped with a 250×250mm aerospace-grade aluminum alloy beam featuring a low-center-of-gravity and large cross-sectional design, it combines lightweight strength with exceptional rigidity, significantly enhancing acceleration, deformation resistance, and precision maintenance—providing robust structural support for every cut.



15-SECOND HIGH-SPEED PARALLEL EXCHANGE

Equipped with a dual-station high-speed exchange table, the system enables parallel table switching in just 15 seconds. Loading/unloading and cutting operations run independently, significantly boosting production efficiency and ensuring seamless continuous operation.

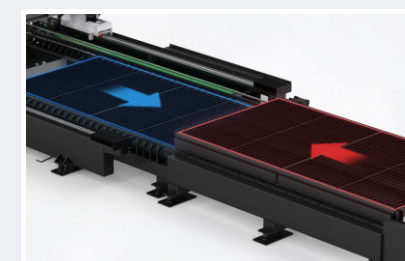



GS-H Series **HIGH-SPEED** **ECO-FRIENDLY**

**COVER EXCHANGED FIBER
LASER METAL SHEET CUTTING MACHINE**



TECHNICAL SPECIFICATIONS

Model	GS-3015H	
Max. material width (mm)	3000×1500 5×10ft	
X axis travel (mm)	1524 / 5.1ft	
Y axis travel (mm)	3030 / 10ft	
Z axis travel (mm)	280 / 0.9ft	
X/Y positioning accuracy	≤0.03mm/m / 0.00118in/39.4in	
X/Y repeat positioning accuracy	≤±0.02mm / 0.00079in	
Max. synthetic positioning speed	140m/min / 460ft/min	
Max. acceleration	2.0G	
Slit width	0.1mm-0.5mm / 0.0039in-0.0197in	
Incision roughness	Ra3.2um-Ra25.4um / Ra0.000126-Ra0.001in	
Max. cutting thickness range	Refer to the following process parameter table	
Min. setting unit	0.001mm / 0.00003937in	
Floor area of machine tool (mm)	10100×4000 33.1×13.2ft	
Host volume (mm)	9200×2300×2350 30×7.5×7.7ft	
CNC system	BOCHU (optional Glorystar system)	
Monitor	27" LCD	
Transfer method	Rack and pinion dual drive	
Max. load-bearing capacity of worktable (tons)	2.2 / 4400lbs	
Total installed power consumption	3000W	27KVA
	6000W	42KVA
	12000W	100KVA
Power requirements	AC380V , 50Hz ; 3P+N+PE	
Total power protection level	IP51	
Instruction	The products provided by the company are optimized and upgraded according to the research and development process. This technical description is suitable for most models. The products purchased by customers may differ from the specified configuration. This manual does not confirm the contract delivery of machinery and equipment.	

RAPID START-STOP WITH MILLISECOND-LEVEL ACCELERATION

This laser cutting machine delivers explosive, millisecond-level acceleration. Its patented hollow bed structure prevents heavy load risks and thermal deformation, boosting bending rigidity by over 50% and ensuring precise, stable processing of medium-to-thick plates.



ADVANCED INTELLIGENT DUST REMOVAL SYSTEM

Equipped with an intelligent dust removal system featuring 8 to 30 automated high-suction zones for efficient smoke extraction. Multi-scenario adaptability, automatic grease lubrication, and an MCA-regulated electrical cabinet, ensuring reliable and efficient operation.

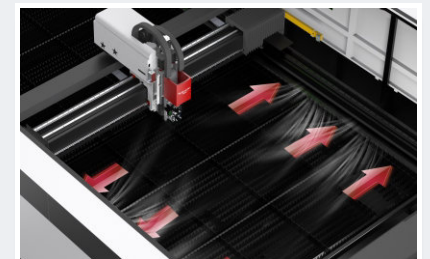

LOW-CENTER-OF-GRAVITY, HIGH-RIGIDITY ALUMINUM ALLOY BEAM

Equipped with a 250×250mm aerospace-grade aluminum alloy beam featuring a low-center-of-gravity and large cross-sectional design, it combines lightweight strength with exceptional rigidity, significantly enhancing acceleration, deformation resistance, and precision maintenance—providing robust structural support for every cut.

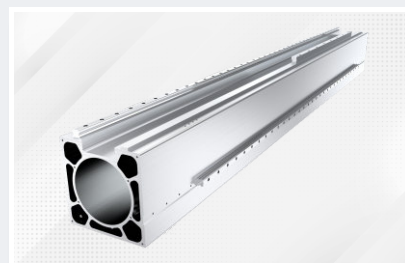

DUAL-STATION HIGH-SPEED EXCHANGE WORKTABLES

The dual-station design enables independent loading/unloading and cutting processes, rapidly switching between tasks to dramatically boost production efficiency and fulfill high-speed continuous processing demands.

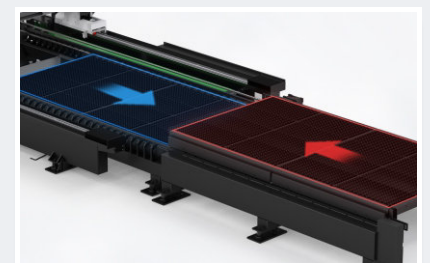

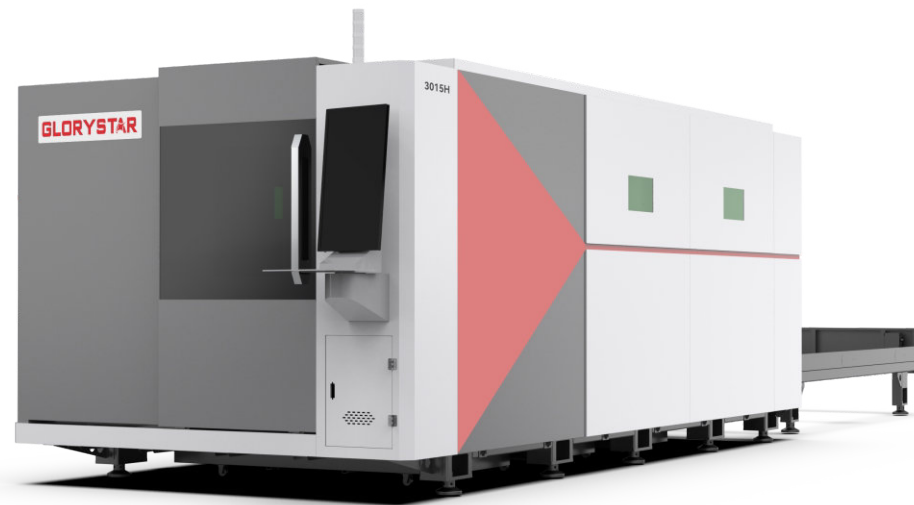

TECHNICAL SPECIFICATIONS

Model	3015H	
Max. material width (mm)	3000×1500 5×10ft	
X axis travel (mm)	1530 / 5.1ft	
Y axis travel (mm)	3048 / 10ft	
Z axis travel (mm)	220 / 0.8ft	
X/Y positioning accuracy	≤0.03mm/m / 0.00118in/39.4in	
X/Y repeat positioning accuracy	≤±0.02mm / 0.00079in	
Max. synthetic positioning speed	140m/min / 460ft/min	
Max. cutting acceleration	1.5G	
Slit width	0.1mm-0.5mm / 0.0039in-0.0197in	
Incision roughness	Ra3.2um-Ra25.4um / Ra0.000126-Ra0.001in	
Floor area of machine tool (mm)	10300×4500 33.8×14.8ft	
Host volume (mm)	9030×2325×2050 29.7×7.7×6.7ft	
CNC system	BOCHU (optional Glorystar system)	
Monitor	27" LCD	
Transfer method	Rack and pinion dual drive	
Max. load-bearing capacity of worktable (tons)	2.2 / 4400lbs	
Total installed power consumption	1500W	20KVA
	3000W	27KVA
	6000W	42KVA
	12000W	100KVA
Power requirements	AC380V , 50Hz ; 3P+N+PE	
Total power protection level	IP51	
Instruction	The products provided by the company are optimized and upgraded according to the research and development process. This technical description is suitable for most models. The products purchased by customers may differ from the specified configuration. This manual does not confirm the contract delivery of machinery and equipment.	

H Series **HIGH-SPEED** **ECO-FRIENDLY**

FULLY ENCLOSED EXCHANGE PLATFORM LASER SHEET CUTTING MACHINE

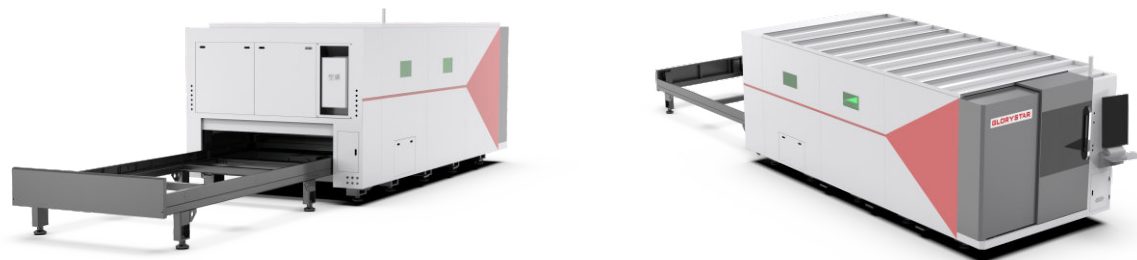

HIGH-SPEED CUTTING / BREAKTHROUGH IN PRODUCTIVITY

Equipped with 1.5G high acceleration and a 7Hz low-pass filtering system, this model significantly outperforms traditional machines in speed. It features a dual-station exchange platform with 15-second rapid switching, allowing simultaneous cutting and loading&unloading, which dramatically enhances processing efficiency.



ECO-FRIENDLY / SPACE-EFFICIENT

Equipped with a patented zoned dust extraction system featuring over 30 high negative pressure suction points, it ensures efficient fume removal while being energy-saving, environmentally friendly and lower costs. The entire machine supports dual-side loading/unloading and bidirectional operation, allowing flexible layouts that adapt to complex workshop spaces — truly maximizing space utilization.



INTELLIGENT PROTECTION / WORRILESS OPERATION

It equipped with industry-leading smart anti-collision human detection system and integrated with door interlock protection, motor torque monitoring, and multiple other safety mechanisms. These features fundamentally prevent operational errors and accidents, ensuring maximum operator safety during high-efficiency operation.

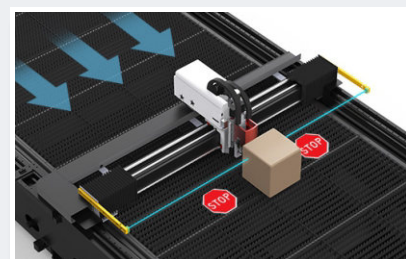

AUTOMATIC LUBRICATION / LOW MAINTENANCE COST

Innovatively equipped with a 16-point XYZ-axis fully automatic grease lubrication system, this solution ensures precise lubrication and maintenance-free operation, greatly reducing the need for manual intervention. High machine stability, significantly lowers maintenance costs, and extends the lifespan of key components by up to 300%, ensuring long-term high-efficiency performance.





VS-CE Series **FAST ROI** **EFFICIENT & DURABLE**

**COVER EXCHANGED
FIBER LASER SHEET CUTTING MACHINE**



TECHNICAL SPECIFICATIONS

Model	VS-3015CE	VS-4015CE	VS-4020CE	VS-6015CE	VS-6020CE	VS-6025CE
Max. material width (mm)	3000×1500 5×10ft	4000×1500 13×10ft	4000×2000 13×7ft	6000×1500 20×5ft	6000×2000 20×7ft	6000×2500 20×8.2ft
X axis travel (mm)	1520 / 5ft	1520 / 5ft	2020 / 7ft	1520 / 5ft	2020 / 7ft	2520 / 8.2ft
Y axis travel (mm)	3030 / 10ft	4030 / 13ft	4030 / 13ft	6030 / 20ft	6030 / 20ft	6030 / 20ft
Z axis travel (mm)	290 / 1ft	290 / 1ft	290 / 1ft	290 / 1ft	290 / 1ft	290 / 1ft
X/Y positioning accuracy	≤0.05mm/m / 0.00197in/39.4in					
X/Y repeat positioning accuracy	≤±0.03mm / 0.00118in					
Max. synthetic positioning speed	150m/min / 492ft/min					
Max. acceleration	2G					
Slit width	0.1mm-0.5mm / 0.0039in-0.0197in					
Incision roughness	Ra3.2um-Ra25.4um / Ra0.000126-Ra0.001in					
Max. cutting thickness range	Refer to the following process parameter table					
Min. setting unit	0.001mm / 0.00003937in					
Floor area of machine tool (mm)	9800×4500 32×15ft	12000×4500 40×15ft	12000×5000 40×16ft	16150×4500 53×15ft	16150×5000 53×16ft	16150×5000 53×16ft
Host volume (mm)	8850×2770×2050 29×9×7ft	10750×2770×2050 35×9×7ft	10750×3310×2050 35×11×7ft	15200×2720×2050 50×9×7ft	15200×3310×2050 50×11×7ft	15200×3810×2050 50×12×7ft
CNC system	BOCHU (optional Glorystar system)					
Monitor	27" LCD					
Transfer method	Rack and pinion dual drive					
Max. load-bearing capacity of worktable (tons)	2.2 / 4850lbs	2.8 / 6173lbs	3.8 / 8378lbs	4.3 / 9480lbs	5.7 / 12567lbs	7.1 / 15653lbs
Total installed power consumption	1500W			20KVA		
	3000W			27KVA		
	6000W			42KVA		
	12000W			100KVA		
Power requirements	AC380V , 50Hz ; 3P+N+PE					
Total power protection level	IP51					
Instruction	The products provided by the company are optimized and upgraded according to the research and development process. This technical description is suitable for most models. The products purchased by customers may differ from the specified configuration. This manual does not confirm the contract delivery of machinery and equipment.					

ULTRA-STABLE HIGH-STRENGTH BED

The high-strength bed structure increases bending stiffness by over 50%, delivering enhanced stability to resolve insufficient rigidity in batch processing. Ensures seamless continuous operation for prolonged productivity.

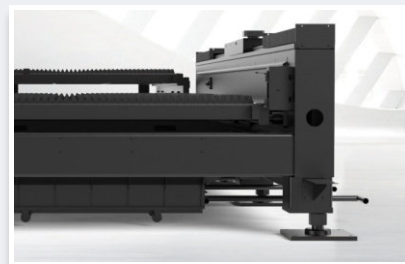

DUAL-STATION HIGH-SPEED SHUTTLE WORKTABLES

Dual-station design enables simultaneous loading/unloading and cutting operations, eliminating downtime. Boosts production efficiency and accelerates processing cycles for high-throughput workflows.

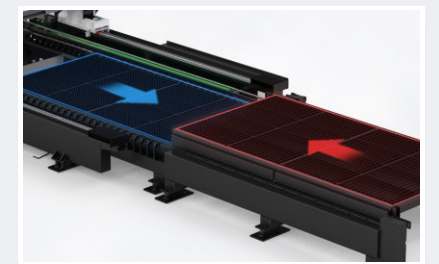

PEAK DYNAMIC PERFORMANCE GUARANTEE

Equipped with dual-drive motors and a high-rigidity beam, this rationally engineered system offers exceptional structural integrity, deformation resistance, and shock absorption. Achieves superior stability and unmatched dynamic processing capabilities.

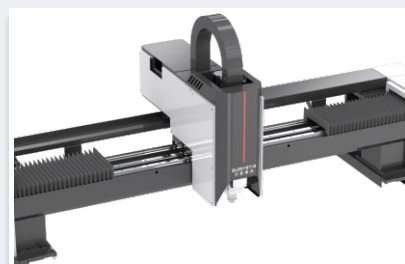

INTELLIGENT STANDARD FEATURES

Factory-equipped with beam light curtain collision prevention, multi-scenario adaptive controls, fully automated grease lubrication, and MCA cabinet climate regulation. Comprehensive safeguards ensure precision, operational safety, and energy-efficient performance.

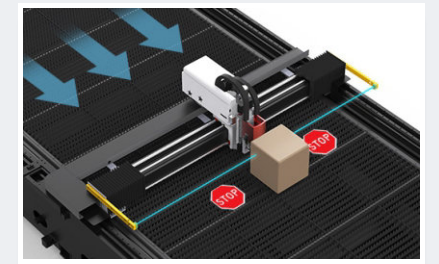



GS-L Series

COMPLIANT WITH EU/US SAFETY STANDARDS

**ULTRA-LARGE FORMAT UNLIMITED
EXTENSION FIBER LASER METAL SHEET CUTTING MACHINE**



TECHNICAL SPECIFICATIONS

Model	GS-13030L	GS-16035L	GS-25035L
Max. material width (mm)	13000×3000 43×10ft bevel cutting: 12500×2500 41×8ft	16000×3500 52×11ft bevel cutting: 15500×3000 49×10ft	25000×3500 82×11ft bevel cutting: 24500×3000 80×10ft
X axis travel (mm)	3050 / 10ft	3550 / 11.7ft	3550 / 11.7ft
Y axis travel (mm)	13050 / 42.8ft	16050 / 52.7ft	25050 / 82.2ft
Z axis travel (mm)	270 / 0.9ft (bevel cutting 430 / 1.4ft)		
X/Y positioning accuracy	≤0.03mm/m / 0.00118in/39.4in		
X/Y repeat positioning accuracy	≤±0.02mm / 0.00079in		
Max. synthetic positioning speed	75m/min / 246ft/min		
Max. acceleration	0.5G		
Drive method	X/Y axis: Rack and pinion, Z axis: Ball screw		
Min. setting unit	0.001mm / 0.00003937in		
Floor area of machine tool (mm)	21000×11500 69×38ft	25000×12000 82×39ft	34000×12000 112×39ft
Host volume (mm)	18700×5600×2600 61×18×9ft	22500×6300×2600 74×21×9ft	31500×6300×2600 103×21×9ft
CNC system	BOCHU		
Monitor	27" LCD		
Transfer method	Refer to the following process parameter table		
Max. load-bearing capacity of worktable (tons)	20 / 44093lbs	35 / 77643lbs	55 / 121753lbs
Total installed power consumption	12000W	100KVA	
	20000W	150KVA	
	30000W	200KVA	
	40000W	300KVA	
	60000W	400KVA	
Power requirements	AC380V , 50Hz ; 3P+N+PE		
Total power protection level	IP51		
Instruction	The products provided by the company are optimized and upgraded according to the research and development process. This technical description is suitable for most models. The products purchased by customers may differ from the specified configuration. This manual does not confirm the contract delivery of machinery and equipment.		

CUSTOMIZED MODULAR SPLIT BED STRUCTURE

Featuring an inner-outer split modular bed design for limitless customization, its separated transmission and plate-loading systems prevent heavy load deformation, boost bending rigidity by over 50%, and deliver enduring high-precision stability.

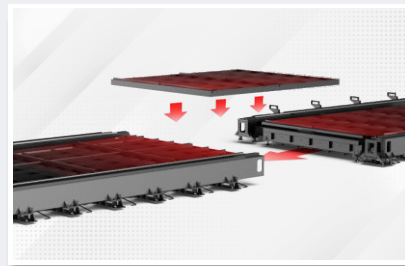

LOW-CENTER-OF-GRAVITY LARGE-SECTION WELDED BEAM

Featuring a 300×400 mm welded beam with a low center of gravity and large cross-section, the lightweight yet strong structure delivers superior acceleration, excellent deformation resistance, and sustained precision for stable, reliable high-speed operation.

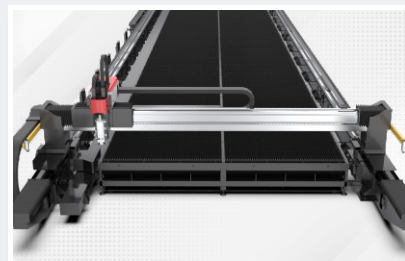

MORTISE-AND-TENON SPLICING AND MODULAR WORKTABLE

The mortise-and-tenon splicing structure significantly enhances precision retention and simplifies efficient equipment calibration. The modular worktable design allows damaged modules to be replaced individually, greatly reducing maintenance costs and improving operational efficiency.

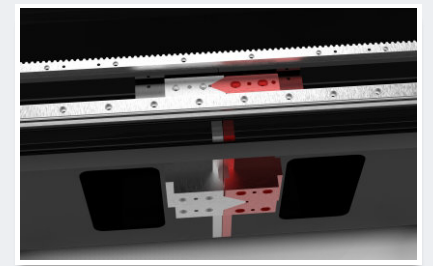

OPTIONAL BEVEL CUTTING / STANDARD INTELLIGENT FUNCTIONS

Optional AB-axis enables multiple bevel cuts (V, Y, X, K) up to +45° in one process, streamlining workflow and cutting costs. Standard features include safety light curtains, multi-scenario adaptability, automatic lubrication, and an MCA cabinet regulator for safe, efficient operation.

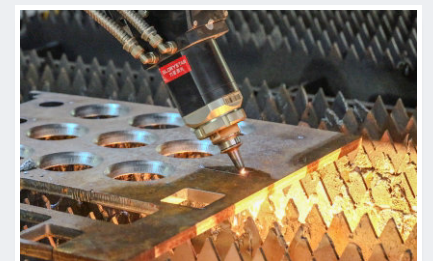



VS Series

SPACE-SAVING

DURABLE

**OPEN TYPE FIBER
LASER SHEET CUTTING MACHINE**



TECHNICAL SPECIFICATIONS

Model	VS-3015	VS-4015	VS-4020	VS-6015	VS-6020	VS-6025	VS-8025
Max. material width (mm)	3000×1500 10×5ft	4000×1500 13×5ft	4000×2000 13×7ft	6000×1500 20×5ft	6000×2000 20×7ft	6000×2500 20×8ft	8000×2500 26×8ft
X axis travel (mm)	1530 / 5ft	1530 / 5ft	2030 / 7ft	1530 / 5ft	2030 / 7ft	2530 / 8.3ft	2530 / 8.3ft
Y axis travel (mm)	3030 / 10ft	4030 / 13ft	4030 / 13ft	6030 / 20ft	6030 / 20ft	6030 / 20ft	8030 / 26.4ft
Z axis travel (mm)	80 / 3.2in						
X/Y positioning accuracy	≤0.05mm/m / 0.00197in/39.4in						
X/Y repeat positioning accuracy	≤±0.03mm / 0.00118in						
Max. synthetic positioning speed	150m/min (when Laser power≤3KW 110m/min) / 492ft/min (when Laser power≤3KW 361ft/min)						
Max. acceleration	2G						
Slit width	0.1mm-0.5mm / 0.0039in-0.0197in						
Incision roughness	Ra3.2um-Ra25.4um / Ra0.000126-Ra0.001in						
Min. setting unit	0.001mm / 0.00003937in						
Floor area of machine tool (mm)	6000×3000 20×10ft	7100×3000 23×10ft	7100×3500 23×12ft	9200×3000 30×10ft	9200×3500 30×12ft	9200×4000 30×13ft	11200×4000 37×13ft
Host volume (mm)	5000×2300×1800 16×8×6ft	6100×2300×1800 20×8×6ft	6100×2900×1800 20×10×6ft	8200×2300×1800 27×8×6ft	8200×2900×1800 27×10×6ft	8200×3500×1800 27×12×6ft	10200×3500×1800 34×12×6ft
CNC system	BOCHU						
Monitor	21.5" LCD						
Transfer method	Rack and pinion dual drive						
Max. load-bearing capacity of worktable (tons)	1.4 / 3087lbs	1.8 / 3969lbs	2.5 / 5512lbs	2.8 / 6173lbs	3.7 / 8157lbs	4.7 / 10362lbs	5.5 / 12126lbs
Total installed power consumption	1500W			20KVA			
	3000W			27KVA			
	6000W			42KVA			
	12000W			100KVA			
Power requirements	AC380V , 50Hz ; 3P+N+PE						
Total power protection level	IP51						
Instruction	The products provided by the company are optimized and upgraded according to the research and development process. This technical description is suitable for most models. The products purchased by customers may differ from the specified configuration. This manual does not confirm the contract delivery of machinery and equipment.						

ULTRA-STRONG BED WITH PEAK DYNAMIC PERFORMANCE ASSURANCE

High-rigidity bed design delivers exceptional structural stability, maintaining micron-level precision even under high-speed/heavy-load operations. Redefines industry benchmarks for dynamic performance in its class.



DUAL-DRIVE MOTORS / HIGH-RIGIDITY BEAM

Integrated dual-drive motor system combined with reinforced beam structure provides exceptional vibration resistance, rigidity, and dynamic stability. Ensures superior cutting accuracy and consistent operation at maximum processing speeds.



MULTI-SCENARIO ADAPTIVE FLEXIBILITY TO PRODUCTION NEEDS

Supports left/right feed hopper configurations for flexible assembly, adaptable to diverse workshop layouts. Eliminates spatial constraints to enable smooth, high-efficiency production workflows.



INTELLIGENT STANDARDIZATION FOR SUSTAINED PRODUCTIVITY

Auto-grease lubrication system maintains optimal component conditions, reducing wear and extending service life. Smart MCA cabinet regulates temperature/humidity, enhancing electrical system reliability. Comprehensive intelligent safeguards ensure uninterrupted 24-hour operation.



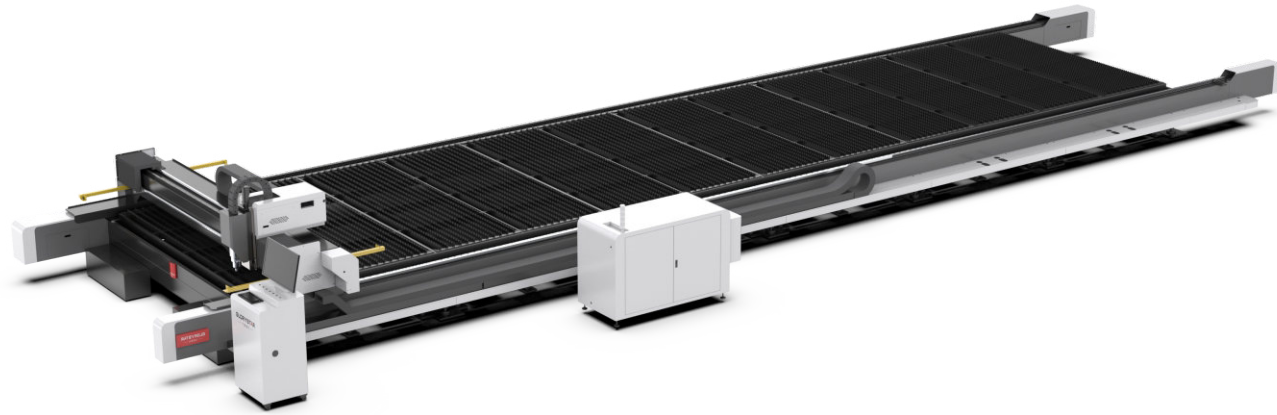

VS-MAX Series **DURABLE** **DEFORMATION-RESISTANT**

**LARGE-FORMAT SINGLE PLATFORM
FIBER LASER SHEET CUTTING MACHINE**

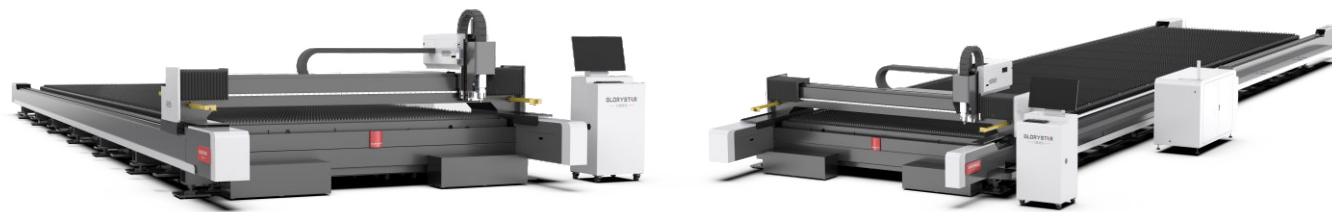

TECHNICAL SPECIFICATIONS

Model	VS-6025MAX	VS-8025MAX	VS-12025MAX	VS-13030MAX	VS-14032MAX
Max. material width (mm)	6000×2500 20×8ft bevel cutting 5200×1700 17×6ft	8000×2500 26×8ft bevel cutting 7200×1700 24×6ft	12000×2500 40×8ft bevel cutting 11200×1700 37×6ft	13000×3000 43×10ft bevel cutting 12200×2200 40×7ft	14000×3200 46×11ft bevel cutting 13200×2400 43×8ft
X axis travel (mm)	2530 / 8ft	2530 / 8ft	2530 / 8ft	3030 / 10ft	3230 / 11ft
Y axis travel (mm)	6050 / 20ft	8050 / 26ft	12050 / 40ft	13050 / 43ft	14050 / 46ft
Z axis travel (mm)	120 / 4.7in				
X/Y positioning accuracy	≤0.03mm/m / 0.00118in/39.4in				
X/Y repeat positioning accuracy	≤±0.02mm / 0.00079in				
Max. synthetic positioning speed	140m/min / 460ft/min				
Max. acceleration	1.5G				
Slit width	0.1mm-0.5mm / 0.0039in-0.0197in				
Incision roughness	Ra3.2um-Ra25.4um / Ra0.000126-Ra0.001in				
Drive method	Rack and pinion dual drive				
Min. setting unit	0.001mm / 0.00003937in				
Floor area of machine tool (mm)	9300×5500 31×18ft	11300×5500 37×18ft	16000×5500 52×18ft	17000×6000 56×20ft	18000×6500 59×21ft
Host volume (mm)	8800×3650×1900 29×12×6ft	10800×3650×1900 35×12×6ft	15600×3650×1900 51×12×6ft	16400×4250×1900 54×14×6ft	17700×4500×1900 58×15×6ft
CNC system	BOCHU (optimal Glorystar system)				
Monitor	27" LCD				
Max. load-bearing capacity of worktable (tons)	10 / 22046lbs	13 / 28660lbs	19 / 41888lbs	25 / 55116lbs	25 / 55116lbs
Total installed power consumption	12000W			100KVA	
	20000W			150KVA	
	30000W			200KVA	
	40000W			300KVA	
Power requirements	60000W			400KVA	
	AC380V , 50Hz ; 3P+N+PE				
Total power protection level	IP51				
Instruction	The products provided by the company are optimized and upgraded according to the research and development process. This technical description is suitable for most models. The products purchased by customers may differ from the specified configuration. This manual does not confirm the contract delivery of machinery and equipment.				

EXTREME DYNAMIC PERFORMANCE ASSURANCE

Dual-bus motors combined with a high-rigidity crossbeam provide exceptional anti-vibration, rigidity, and stability, redefining peak dynamic performance in its class and offering robust support for high-intensity continuous cutting.



MODULAR WORKTABLE FOR COST REDUCTION

The modular design breaks down the worktable into manageable sections, facilitating quick replacement and maintenance, significantly lowering usage and maintenance costs, and enhancing operational efficiency.

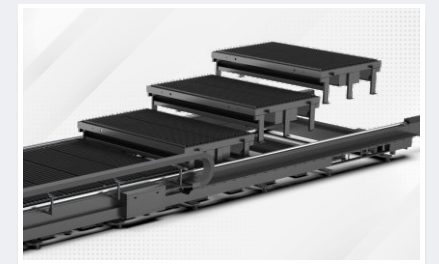

INNER-OUTER SPLIT BED DESIGN

The separation of the transmission system and the plate-bearing system ensures high rigidity and stability, maintaining excellent processing accuracy even under continuous cutting conditions.



INTEGRATED MULTI-FUNCTIONAL BEVEL CUTTING

Equipped with an AB swing axis supporting various bevel cuts such as V, Y, and X, achieving bevel angles up to +45° in a single process, reducing the need for additional beveling steps and helping to cut costs and increase efficiency.

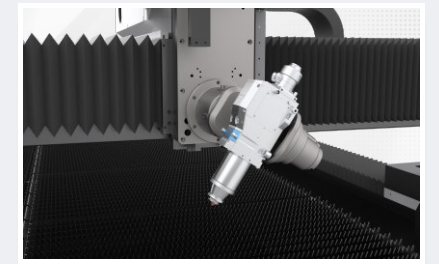



GS-C Series

SPACE-SAVING

DURABLE

**FULLY ENCLOSED SIDE-FED
FIBER LASER SHEET CUTTING MACHINE**



TECHNICAL SPECIFICATIONS

Model	GS-1510C	GS-3015C	GS-4020C
Max. material width (mm)	1500×1000 5×3.3ft	3000×1500 10×5ft	4000×2000 13.2×6.6ft
X axis travel (mm)	1020 / 3.4ft	3020 / 10ft	4020 / 13.2ft
Y axis travel (mm)	1520 / 5ft	1500 / 5ft	2000 / 6.6ft
Z axis travel (mm)		95 / 3.8in	
X/Y positioning accuracy		≤0.03mm/m / 0.00118in/39.4in	
X/Y repeat positioning accuracy		≤±0.02mm / 0.00079in	
Max. synthetic positioning speed		140m/min / 460ft/min	
Max. acceleration		1.5G	
Slit width		0.1mm-0.5mm / 0.0039in-0.0197in	
Incision roughness		Ra3.2um-Ra25.4um / Ra0.000126-Ra0.001in	
Transfer method		Rack and pinion dual drive	
Min. setting unit		0.001mm / 0.00003937in	
Floor area of machine tool (mm)	4000×3000 13×10ft	6000×2500 19.7×8.2ft	8000×3850 26.3×12.7ft
Host volume (mm)	3130×2750×2300 10.3×9×7.6ft	5100×2400×2300 16.8×7.9×7.6ft	6200×3760×2300 20.4×12.4×7.6ft
CNC system		BOCHU (optimal Glorystar system)	
Monitor		27" LCD	
Max. bearing capacity of workbench (tons)	0.75 / 1654lbs	1 / 2205lbs	1.8 / 3969lbs
Total installed power consumption	1500W		19.5KVA
	3000W		27KVA
	6000W		42KVA
Power requirements		AC380V , 50Hz ; 3P+N+PE	
Total power protection level		IP51	
Instruction	The products provided by the company are optimized and upgraded according to the research and development process. This technical description is suitable for most models. The products purchased by customers may differ from the specified configuration. This manual does not confirm the contract delivery of machinery and equipment.		

HIGH-STRENGTH MORTISE AND TENON MACHINE BED

The machine bed adopts a high-strength mortise-and-tenon structural design, providing outstanding resistance to bending, vibration, torsion, and deformation. Even during long-term continuous cutting, it maintains high processing accuracy and stable performance.



ECO-FRIENDLY ZONAL DUST EXTRACTION SYSTEM

Equipped with 8 to 30 fully automatic high-suction negative pressure dust removal units, this system ensures smooth smoke exhaust and high dust collection efficiency. The zoned extraction design enhances environmental protection, reduces operational costs, keeps the workspace clean and safe.

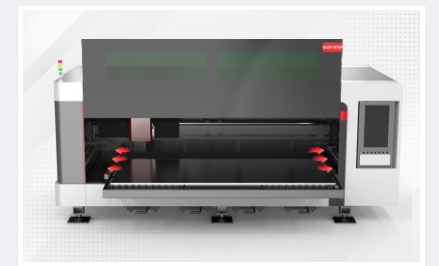

USER-FRIENDLY DESIGN DETAILS

Equipped with a pull-out work table for quick loading and unloading, this machine saves time and labor in automated cutting operations. An auto-lifting front protective door prevents metal slag splashes, ensuring operator safety, while large-format laser safety panels provide dual-layer protection with laser isolation, explosion resistance, and flame retardancy.

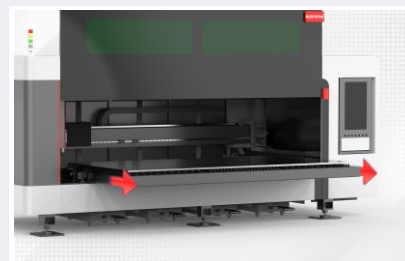

LOW CENTER OF GRAVITY / LARGE-SECTION CROSSBEAM

The low center of gravity combined with a large cross-section crossbeam design allows for higher acceleration and increased output per unit time. The crossbeam is made of lightweight yet high-strength materials, offering excellent durability, deformation resistance, and precision retention.



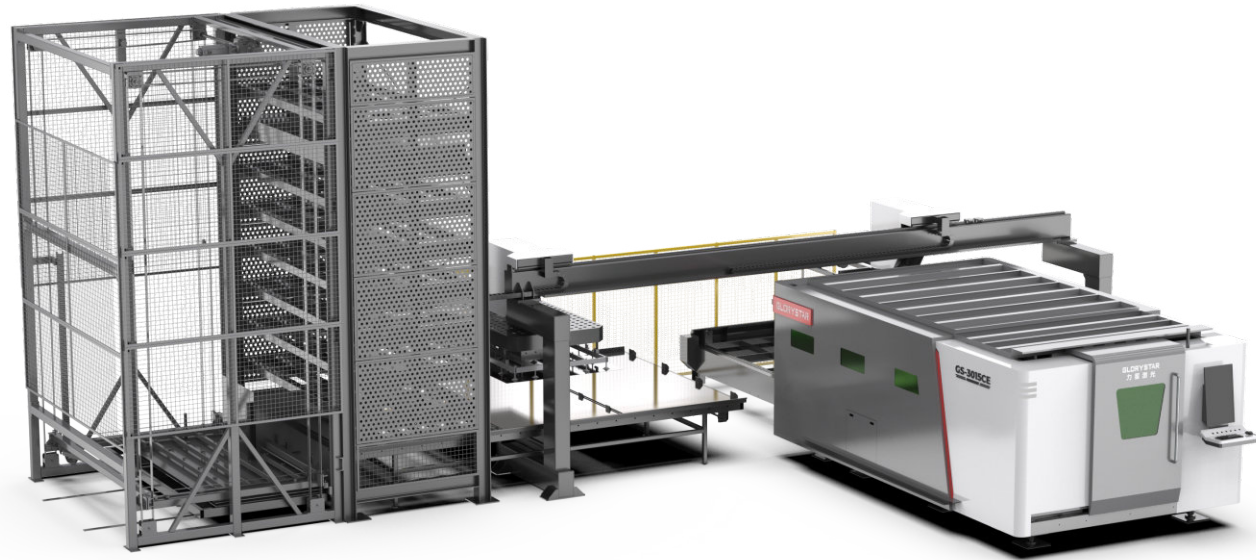

AUTOMATED MATERIAL STORAGE AND RETRIEVAL SYSTEM FOR LASER CUTTING MACHINES



TECHNICAL SPECIFICATIONS

Model	SCL3015-3-1	SCL4020-3-1
Thickness of plate	1-6mm / 0.04-0.24in	1-6mm / 0.04-0.24in
Maximum size of loading plate	3000×1500mm / 10×5ft	4000×2000mm / 13×6.6ft
Maximum size of unloading plate	1220×1250mm / 4×4.1ft	1500×1500mm / 5×5ft
Maximum weight of workpiece	212kg / 468lbs	376kg / 829lbs
Maximum horizontal speed X-axis	30m/min / 98.5ft/min	25m/min / 82ft/min
Maximum vertical speed Z-axis	15m/min / 49.2ft/min	8m/min / 26.3ft/min
X-axis travel	7000mm / 23ft	9000mm / 30ft
Z-axis travel	900mm / 3ft	900mm / 3ft
Maximum load of cart	3000kg / 6614lbs	3000kg / 6614lbs
Maximum speed of cart	12m/min / 39.4ft/min	12m/min / 39.4ft/min
Total power of motor	3.5Kw	5Kw
Air supply pressure	0.6Mpa	0.6Mpa
Overall dimensions	9380×7100×2650mm / 31×23.3×8.7ft	11500×9500×2650mm / 37.8×31.2×8.7ft

EFFICIENT STORAGE AND INTELLIGENT MATERIAL HANDLING

Utilizes a tower-type three-dimensional storage structure for systematic bulk storage of sheet materials, effectively maximizing vertical space and providing organized, high-efficiency raw material management as a solid foundation for production.

AUTOMATIC SHEET SEPARATION AND PRECISE DETECTION

Automatic sheet separation, thickness detection, production scheduling, and material selection enable scientifically optimized usage, ensuring each step in the workflow is precise and efficient to support process optimization.

ONE-STOP AUTOMATED OPERATION

An independent control system enables fully automated operation covering material retrieval, loading, cutting, and unloading—greatly improving work efficiency while reducing manual intervention and operational risks.

MULTI-MACHINE INTEGRATION AND MODULAR CUSTOMIZATION

Supports one-to-many configuration, allowing a single system to operate multiple laser machines. Flexible modular customization is available: select loading system styles, number of columns, and layer capacity as needed, meeting diverse production scale requirements.

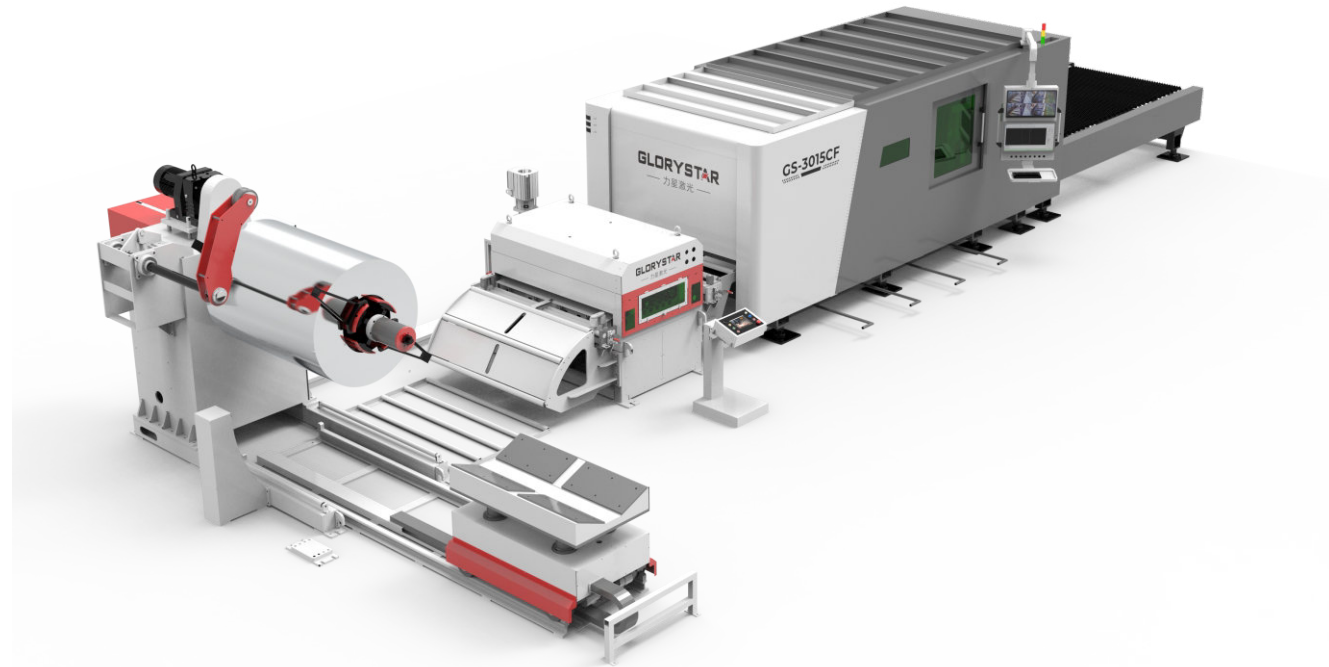

GS-CF Series

UNCOILING AND LEVELING LASER CUTTING LINE



TECHNICAL SPECIFICATIONS

Model	1600mm Uncoiling Line	1300mm Uncoiling Line
Maximum Coil Weight	15000kg / 33070lbs	6000kg / 13228lbs
Coil Width	200 - 1524mm / 7.9 - 60in	200 - 1300mm / 7.9 - 51in
Coil Outer Diameter	Φ800 - Φ1500mm / Φ31.5 - Φ59.1in	Φ800 - Φ1300mm / Φ31.5 - Φ51.1in
Coil Inner Diameter	Φ508 - Φ610mm / Φ20.1 - Φ24.1in	Φ508 - Φ610mm / Φ20.1 - Φ24.1in
Coil Thickness	0.6 - 2.0mm (Stainless Steel) ≤1524mm 0.03 - 0.08in (Stainless Steel) ≤60in 0.8 - 3.0mm (Carbon Steel) ≤1524mm 0.032 - 0.12in (Carbon Steel) ≤60in	0.6 - 1.8mm (Stainless Steel) ≤1250mm 0.02 - 0.07in (Stainless Steel) ≤49in 0.8 - 2.0mm (Carbon Steel) ≤1250mm 0.032 - 0.08in (Carbon Steel) ≤49in
Feeding Length	0 - Maximum Travel of Equipment	0 - Maximum Travel of Equipment
Uncoiling Speed	0-15mm/s / 0-0.6in/s	0 - 15mm/s / 0-0.6in/s
Moving Speed	0-8mm/s / 0-0.3in/s	0-8mm/s / 0-0.3in/s
Lifting Speed	3.0mm/s / 0.12in/s	3.0mm/s / 0.12in/s
Lifting Stroke	350mm / 13.8in	350mm / 13.8in
Leveling Flatness	≤±3mm/m ²	≤±3mm/m ²
Fixed Feeding Line Height	870 / 34.3in	870 / 34.3in
Fixed Length Accuracy	Length Direction≤±0.2mm/m Diagonal Direction≤±0.8mm/m	Length Direction≤±0.2mm/m Diagonal Direction≤±0.8mm/m

AUTOMATIC CENTERING AND PRECISE INTEGRATION

The coil is positioned onto the feeding combine vehicle by the coil field crane and then automatically transported by the feeding cart to the unwinder. After manual visual centering, the coil smoothly enters the leveling and feeding machine, ensuring a stable, continuous production flow.

PRECISE SENSING AND AUTOMATIC START-STOP

During continuous laser cutting, the coil material in the pit gradually rises. Upon reaching a preset height, a photoelectric reflector sends a signal to the unwinding device to automatically resume feeding, ensuring balanced material supply for efficient, automated processing.

INTELLIGENT ADJUSTMENT TO ENSURE CONTINUOUS OPERATION

A material arc compensation system between the coil rack and the leveling device automatically adjusts the speed differences among the unwinding, leveling, and laser cutting processes. Real-time monitoring by a photoelectric reflector stops the motor when the coil material descends to the lower limit, preventing overfeeding and ensuring cutting precision.

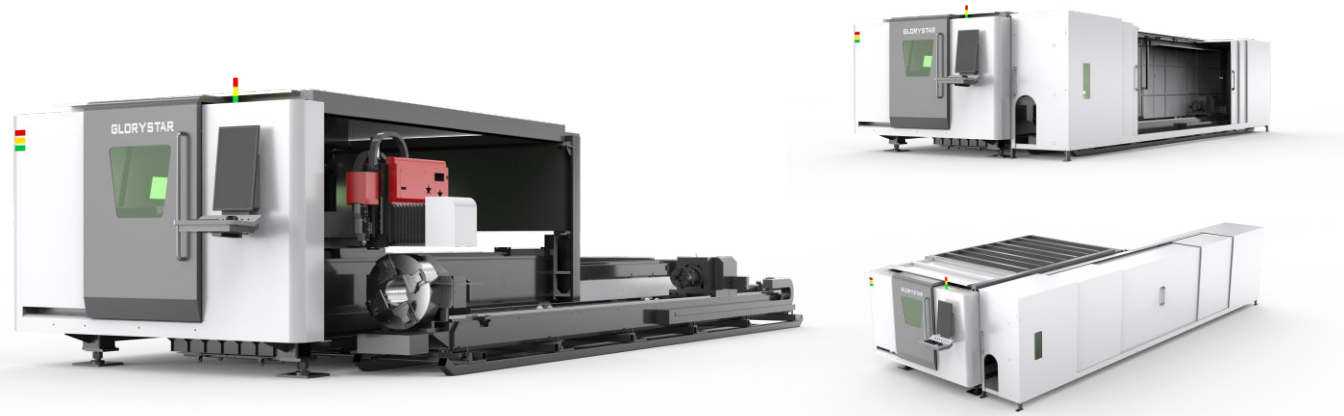

GS-CEG Seires

FULLY ENCLOSED SHEET / TUBE COMBINED FIBER LASER CUTTING MACHINE

- | Integrated plate and tube cutting capabilities for multi-purpose use.
- | Dual-station high-speed exchange worktable ensures efficient cutting.
- | Maximum processing length: 6m; maximum round/square tube processing diameter: 220mm.

Model	GS-3015CEG (Customizable for different format)
Working Area	3000*1500mm / 5*10ft
Laser Power	3000-6000W
Positioning Accuracy	±0.03mm / ±0.0012in
Repeat Positioning Accuracy	±0.02mm / ±0.0008in
Overall Dimensions	10100*4500*2200mm / 33*15*7.2ft



VS-G Series

OPEN TYPE SHEET / TUBE COMBINED FIBER LASER CUTTING MACHINE

- | Integrated cutting for both plates and tubes, offering versatile applications.
- | Maximum processing length: 6m; maximum round tube processing diameter: 220mm.

Model	VS-3015G
Working Area	3000*1500mm / 5*10ft
Laser Power	1000-6000W
Positioning Accuracy	±0.05mm / ±0.00197in
Repeat Positioning Accuracy	±0.03mm / ±0.00118in
Overall Dimensions	8500*3300*1800mm / 27.9*11*6ft



VS-CEG Series

FULLY ENCLOSED SHEET / TUBE COMBINED FIBER LASER CUTTING MACHINE

- | Combines sheet and tube cutting in one machine, expanding processing capabilities and increasing added value.
- | High-Performance Chuck. Features strong clamping force, high rigidity, fast speed, and stable performance.
- | Rapid Exchange Platform. Enables efficient cutting with quick material switching.

Model	VS-3015CEG
Working Area	3000*1500mm / 5*10ft
Laser Power	1000-6000W
Positioning Accuracy	≤0.03mm / ≤0.00118in
Repeat Positioning Accuracy	≤±0.02mm / ≤±0.00079in
Overall Dimensions	9500*4500*2050mm / 33*15*7.2ft

SAMPLES

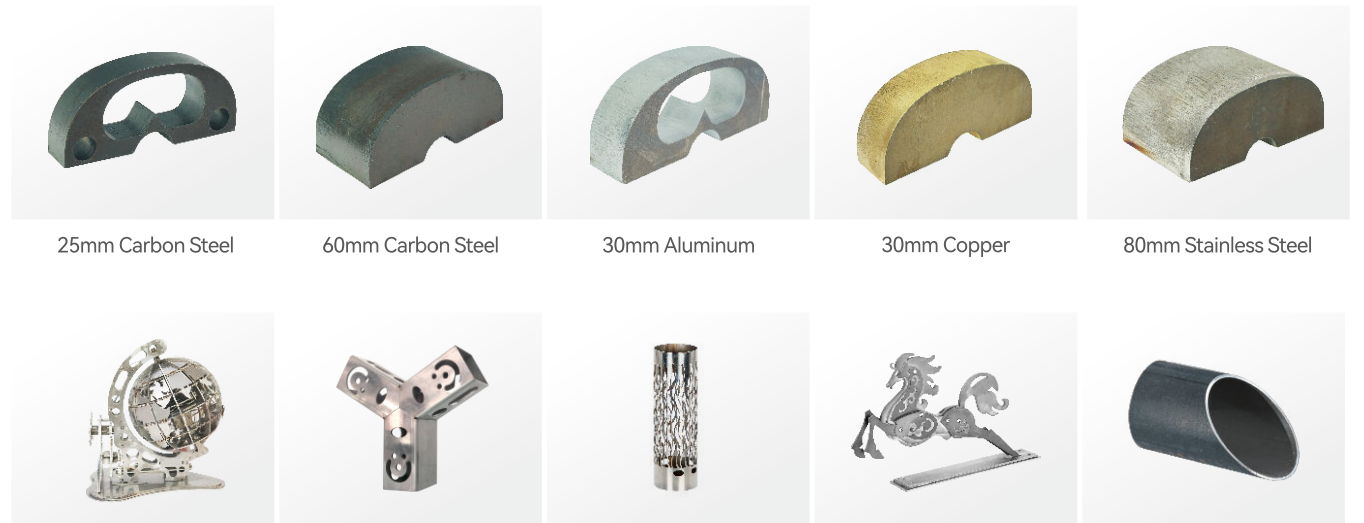

25mm Carbon Steel

60mm Carbon Steel

30mm Aluminum

30mm Copper

80mm Stainless Steel

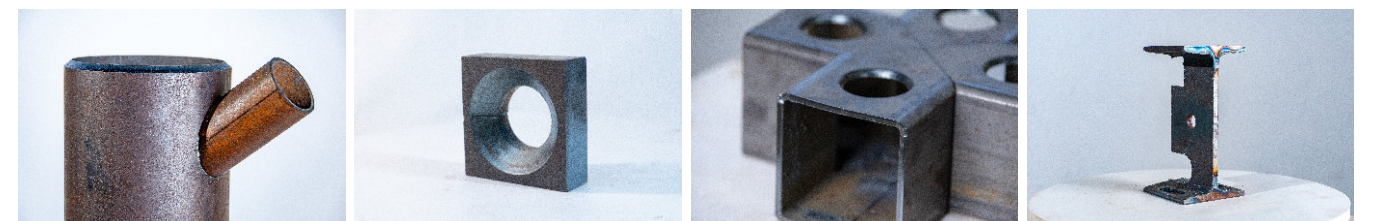

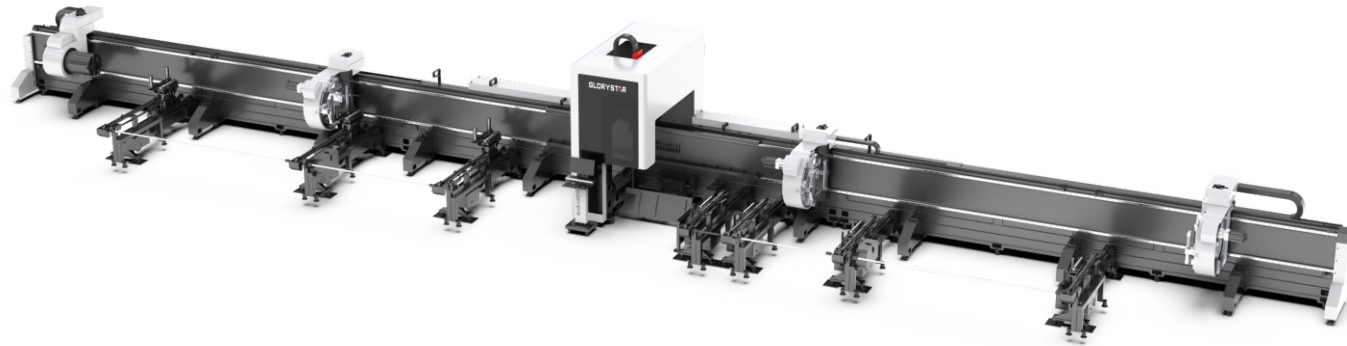

NS-FG Series **HIGH PRECISION** **HEAVY-DUTY**

FOUR-CHUCK HEAVY-DUTY FIBER LASER TUBE CUTTING MACHINE



TECHNICAL SPECIFICATIONS

Model	NS-13056FG
Max. Pipe Size	13000mm×Φ550mm / 42.7×Φ1.8ft
Repeat Positioning Accuracy	≤0.05mm / ≤0.02in
Positioning Accuracy	≤0.1mm / ≤0.04in
Max. Positioning Speed	50m/min / 164ft/min
Max. Bevel Angle	±45°
Max. Acceleration	0.3G
Max. Chuck Speed	30r/min
Pipe Weight	≤1800Kg / ≤3968lbs
Machine Weight	33T / 73920lbs
Machine Footprint	30000×5000mm / 98.4×16.4ft
Power Input	380VAC, 50Hz
Round Pipe Processing Range	Φ50mm - Φ550mm / Φ2in - Φ21.7in
Square Pipe Processing Range	50×50mm - 400×400mm / 2×2in - 15.7×15.7in

OPTIONAL BEVEL CUTTING FUNCTION

The bevel cutting function is available as an optional configuration. It uses a swing arm mechanism to rotate the cutting head, which features a 90° fixed angle to prevent excessive fiber movement during oscillation. The cutting head comes standard with air pressure monitoring, temperature detection, and anti-collision protection, ensuring safety and stability during processing.



MODULAR HIGH-STRENGTH BED

The bed is welded with a high-strength cage structure, which is annealed at high temperature and processed by gantry milling. It has the characteristics of earthquake resistance, torsion resistance and deformation resistance. The bed adopts a modular combination structure, and the length of loading and unloading can be customized according to needs to meet different production needs.



FOUR-CHUCK ZERO TAIL MATERIAL CUTTING

The full-stroke four-chuck structure effectively prevents the shaking of the pipe from affecting the cutting accuracy, realizes stable unloading, does not require manual intervention, maximizes the use of materials, and reduces production costs.

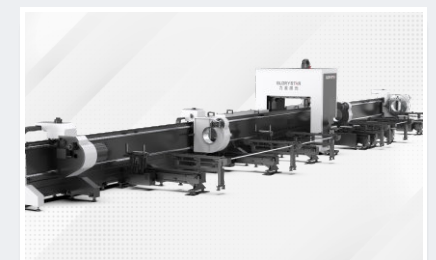

INTELLIGENT LOADING AND UNLOADING SYSTEM

Equipped with a standard tube length measurement device and servo-driven support system, the machine ensures stable and accurate loading. On the unloading side, the support spacing is optimized to accommodate workpieces of various lengths. This fully automated system eliminates the need for manual assistance, significantly enhancing production efficiency.





NS-HG Series

ECO-FRIENDLY

HIGHLY AUTOMATED

THREE-CHUCK PROFESSIONAL FIBER LASER TUBE CUTTING MACHINE



TECHNICAL SPECIFICATIONS

Model	NS-6024HG
Max. Pipe Size	6500mm×Φ230mm / 21.3ft×Φ8.9in
Repeat Positioning Accuracy	≤0.03mm / ≤0.0012in
Positioning Accuracy	≤0.05mm / ≤0.002in
Max. Positioning Speed	80m/min / 262.5ft/min
Max. Bevel Angle	±45° (optional)
Max. Acceleration	1.0G
Max. Chuck Speed	100r/min
Pipe Weight	≤260Kg / ≤573.2lbs
Machine Weight	10T / 22046lbs
Machine Footprint	18500×2500mm / 60.7×8.2ft
Power Input	380VAC, 50Hz
Round Pipe Processing Range	Φ15mm - Φ230mm / Φ0.6in - Φ9.1in
Square Pipe Processing Range	15×15mm - 230×230mm / 0.6×0.6in - 9.1×9.1in
I-Beam Processing Range	5-20# (50×37mm-200×102mm / 2×1.5in~7.8×4in)

FULLY AUTOMATIC HIGH-EFFICIENCY SAFETY SYSTEM

Seamlessly integrates with fully automated material storage and loading/unloading. Servo-driven for ultra-high sorting and loading efficiency, remote operation, and comprehensive, high-intensity safety throughout the process.



HIGH-PRECISION FULL-TUBE CUTTING AND ZERO-TAIL PROCESSING

A specialized pipe-cutting chuck with a full-stroke pneumatic design guarantees clamping concentricity within 0.1mm and roller roundness accuracy of 0.003. It supports whole pipe handling (up to 6m) and, with an innovative mobile beam, achieves precise dual-end cutting and zero-tail processing.



SUPERIOR STRUCTURAL DESIGN AND PRECISION SUPPORT

A high-strength, side-mounted chuck bed is high-temperature annealed to eliminate internal stresses and defects, preventing deformation and cracking. Variable diameter wheel supports and centering clamps ensure solid, precise support for long-term, stable small tube cutting.

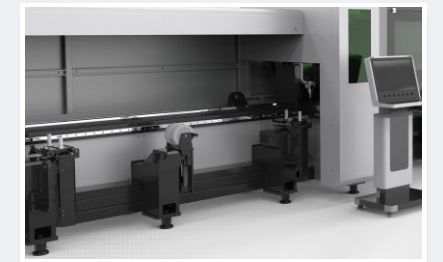

MULTI-MODE BEVEL CUTTING AND PROFESSIONAL DUST REMOVAL

Features premium bevel cutting heads with flying cutting and high-precision Z-axis control, offering multiple bevel modes (V, X, Y, K) with ±45° adjustment. Integrated internal/external dust removal systems and patented dust-proof guide rails ensure complete protection.

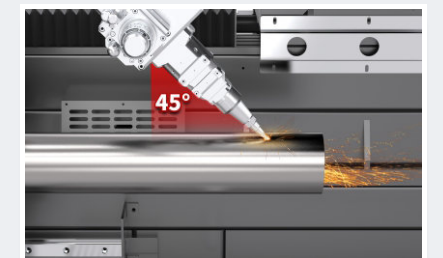

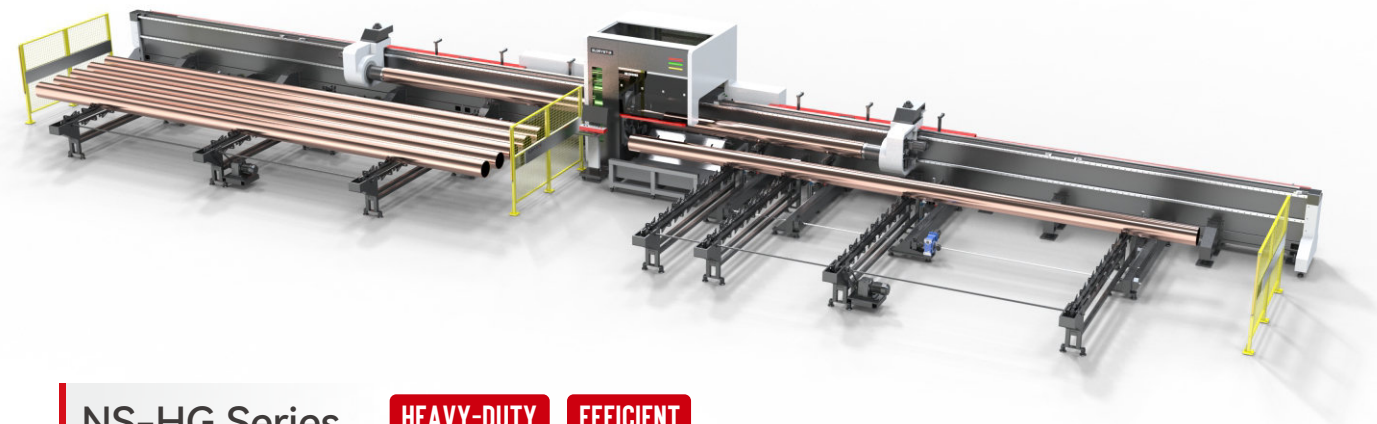

NS-HG Series **HEAVY-DUTY** **EFFICIENT**

THREE-CHUCK HEAVY-DUTY FIBER LASER TUBE CUTTING MACHINE

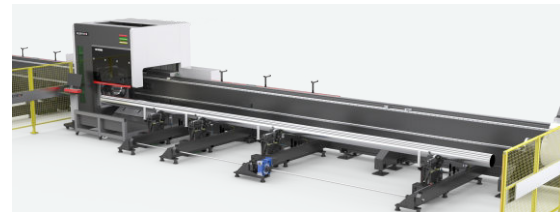
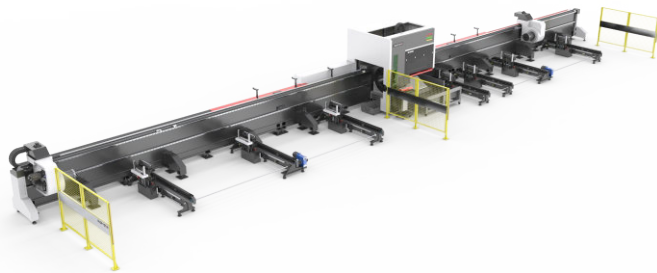

TECHNICAL SPECIFICATIONS

Model	NS-12036HG	NS-12056HG
Max. Pipe Size	12300mm×Φ360mm / 40.3ft×Φ1.18ft	12300mm×Φ550mm / 40.3ft×Φ1.8ft
Repeat Positioning Accuracy	≤0.05mm / ≤0.002in	≤0.05mm / ≤0.002in
Positioning Accuracy	≤0.1mm / ≤0.004in	≤0.1mm / ≤0.004in
Max. Positioning Speed	50m/min / 164ft/min	50m/min / 164ft/min
Max. Bevel Angle	±45° (optional)	±45° (optional)
Max. Acceleration	0.5G	0.3G
Max. Chuck Speed	50r/min	30r/min
Pipe Weight	≤1000Kg / ≤2205lbs	≤1800Kg / ≤3968lbs
Machine Weight	25T / 55116lbs	29T / 63835lbs
Machine Footprint	30000×5000mm / 398×16.4ft	30000×5000mm / 398×16.4ft
Power Input	380VAC, 50Hz	380VAC, 50Hz
Round Pipe Processing Range	Φ40mm-Φ360mm / Φ1.6in-Φ14.2in	Φ50mm - Φ550mm / Φ2in-Φ21.6in
Square Pipe Processing Range	40×40mm-360×360mm / 1.6×1.6in-14.2×14.2in	50×50mm - 400×400mm / 2×2in-15.8×15.8in
I-Beam Processing Range	10-32# (100x70mm-300x152mm / 3.9x2.8in-11.8x6in)	10-50# (100x70mm-500x202mm / 3.9x2.8in-20x8in)

PRECISION AND DURABLE DESIGN

The high-strength side-mounted chuck bed undergoes high-temperature annealing to eliminate internal stress and structural defects, preventing deformation and cracking for long-term stable operation. The full-stroke pneumatic precision chuck achieves clamping concentricity under 0.1mm and roller roundness accuracy of 0.003mm, offering top-tier precision and strong clamping force to meet high-accuracy cutting requirements.



EFFICIENT AND SAFE LOADING/UNLOADING SYSTEM

Features intelligent telescopic loading grippers and anti-collision unloading grippers to enhance material handling speed, accommodating various pipe lengths and positions. The multi-pipe storage and single-pipe loading support design keeps pipes away from the machine bed, boosting efficiency and reducing safety risks, thus protecting both equipment and materials.



INTELLIGENT ZERO-TAIL CUTTING

The full-stroke mobile design supports precise cutting at both pipe ends, achieving zero-tail material processing. This increases material utilization, reduces waste, lowers production costs, and meets the needs of efficient production and fine processing.



PROFESSIONAL DUST REMOVAL AND VERSATILE PROFILE PROCESSING

Equipped with internal and external dust removal systems and patented dust-proof designs, the machine ensures a clean work environment and extended service life. It handles standard and special-shaped pipes in various metals like carbon steel, stainless steel, copper, and aluminum, meeting diverse processing needs.

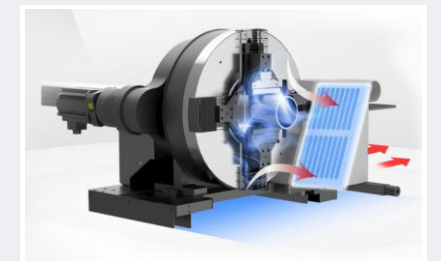



GS-TG Series

CLEAN CUTTING **HIGH PRECISION**

**DUAL-CHUCK FIBER LASER
TUBE CUTTING MACHINE**



TECHNICAL SPECIFICATIONS

Model	GS-6024TG	GS-12036TG
Max. Pipe Size	6500mm×Φ230mm / 21.3ft×Φ8.9in	12300mm×Φ360mm / 40.3ft×Φ14.2in
Repeat Positioning Accuracy	≤0.03mm / ≤0.0012in	≤0.05mm / ≤0.002in
Positioning Accuracy	≤0.05mm / ≤0.002in	≤0.1mm / ≤0.004in
Max. Positioning Speed	80m/min / 262.5ft/min	50m/min / 164ft/min
Max. Acceleration	1G	0.5G
Max. Chuck Speed	100r/min	50r/min
*Max. Bevel Angle	±45° (optional)	±45° (optional)
Pipe Weight	≤260Kg / ≤573.2lbs	≤1000Kg / ≤2205lbs
Machine Weight	6T / 13227lbs	10T / 22046lbs
Machine Footprint	11000×2500mm / 36×8ft	19000×2500mm / 62×8ft
Power Input	380VAC, 50Hz	380VAC, 50Hz
Round Pipe Processing Range	Φ15mm-Φ230mm / Φ0.6in-Φ8.9in	Φ30mm-Φ360mm / Φ1.2in-Φ14.2in
Square Pipe Processing Range	15×15mm-230×230mm / 0.6×0.6in-8.9×8.9in	30×30mm - 360×360mm / 1.2×1.2in-14.2×14.2in
I-Beam Processing Range	5-20# (50x37mm-200x102mm / 2x1.5in-14.2x5.5in)	10-36# (100x70mm-360x140mm / 3.9x2.8in-14.2x5.5in)

*This feature is a function of the upgraded Pro series products.

CLEANING AND HIGH-EFFICIENCY DUST REMOVAL SYSTEM

Rear chuck features a hollow dust extraction design—with an optional front-mounted slag removal unit—to minimize slag residue. Coupled with dust extraction in both the cutting area and tube interior, plus patented dust-proof guide rails and racks, it ensures a consistently clean environment and improved processing quality.

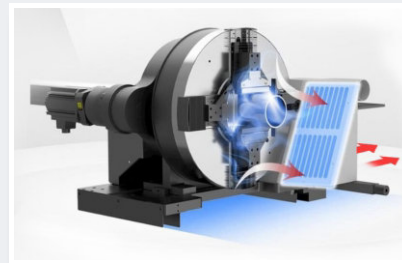

RUGGED AND DURABLE HIGH-STRENGTH STRUCTURE

The high-strength side-mounted chuck bed is high-temperature annealed to eliminate internal stresses and defects, effectively preventing deformation and cracking, ensuring stable and reliable operation during extended high-intensity use.

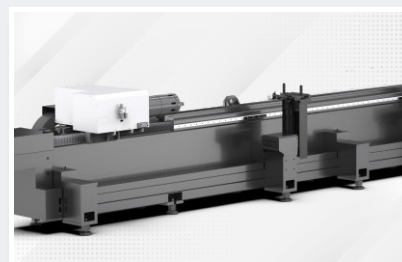

HIGH-PRECISION AND SHORT-TAIL REMNANT CUTTING SYSTEM

A dedicated tube-cutting chuck employing full-stroke pneumatic technology achieves clamping concentricity within 0.1 mm and spindle roundness of 0.003 mm for superior accuracy and clamping force. It also supports short-tail cutting by allowing the rear chuck to pass through the front chuck for precise remnant processing.

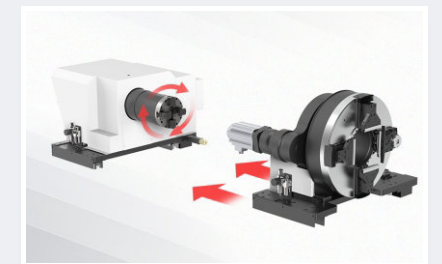

MULTI-FUNCTIONAL BEVEL CUTTING OPTION

The specialized bevel cutting head and system from a leading international brand is available as an option, supporting fly cutting, high-precision Z-axis control, and multi-axis bevel cutting configurations. It can perform V/X/Y/K bevel profiles, and supports bevel angle adjustment up to ±45°, fully meeting diverse processing needs.





VS-TG Series

EFFICIENT DURABLE

**DUAL-CHUCK FIBER LASER
TUBE CUTTING MACHINE**

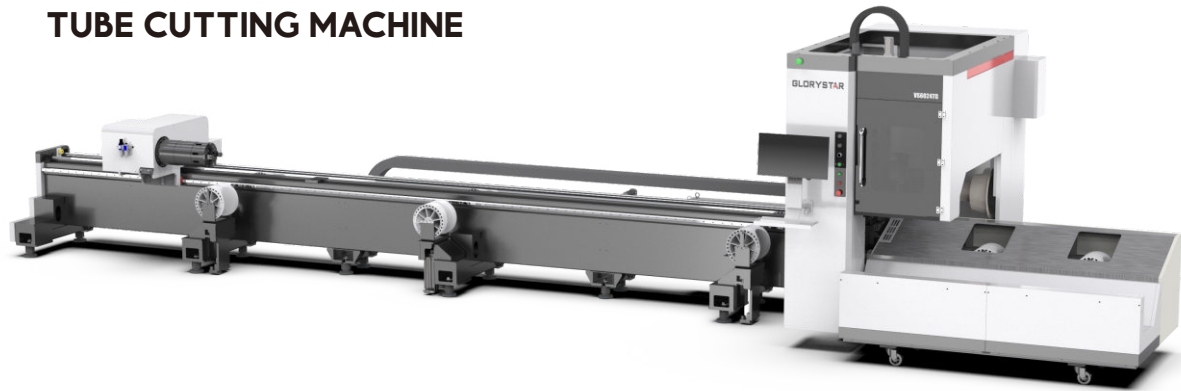

TECHNICAL SPECIFICATIONS

Model	VS-6024TG	VS-6036TG
Max. Pipe Size	6200mm×Φ230mm / 20.3ft×Φ8.9in	6900mm×Φ360mm / 22.6ft×Φ14.2in
Repeat Positioning Accuracy	≤0.03mm / ≤0.012in	≤0.05mm / ≤0.002in
Positioning Accuracy	≤0.05mm / ≤0.002in	≤0.1mm / ≤0.004in
Max. Positioning Speed	80m/min / 262.5ft/min	50m/min / 164ft/min
Max. Acceleration	1.0G	0.5G
Max. Chuck Speed	100r/min	50r/min
Pipe Weight	≤260Kg / ≤573.2lbs	≤1000Kg / ≤2205lbs
Machine Weight	3.5T / 7716lbs	6T / 13227lbs
Machine Footprint	9000×2500mm / 29.5×8ft	10000×2500mm / 32×8ft
Power Input	380VAC, 50Hz	380VAC, 50Hz
Round Pipe Processing Range	Φ15mm-Φ230mm / Φ0.6in-Φ8.9in	Φ30mm-Φ360mm / Φ1.2in-Φ14.2in
Square Pipe Processing Range	15×15mm-230×230mm / 0.6×0.6in-8.9×8.9in	30×30mm - 360×360mm / 1.2×1.2in-14.2×14.2in
I-Beam Processing Range	5-20# (50x37mm~200x102mm / 2x1.5in~14.2x5.5in)	10-36# (100x70mm~360x140mm / 3.9x2.8in~14.2x5.5in)

ALL-ROUND DUST REMOVAL SYSTEM

Equipped with a dual dust removal system—inside the tube and in the cutting area—this design efficiently eliminates dust and residue (slag deposits) generated during operation, ensuring the tube interior and cutting zone remain consistently clean and improving processing quality.

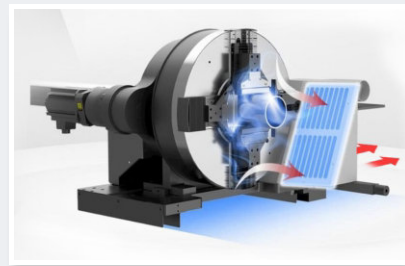

DURABLE AND ROBUST SUPPORT STRUCTURE

Variable-diameter wheel supports improve stability during loading. The annealed machine bed eliminates internal stress and defects, preventing deformation. Modular design simplifies maintenance and ensures long-term reliability.



EFFICIENT SHORT-TAIL CUTTING AND AUTOMATIC LOADING

Supports short-tail material cutting, with the rear chuck able to pass through the front chuck for precise end trimming. An optional automatic material storage and loading system enables fast, efficient feeding, boosting both productivity and material utilization.



TOP-TIER PRECISION TUBE CUTTING SYSTEM

The high-performance chuck, specifically designed for tube cutting, features full-stroke pneumatic technology. It delivers clamping precision (concentricity < 0.1 mm) and roller roundness accuracy of 0.003 mm, ensuring precise and stable cutting of both small and medium-sized tubes.

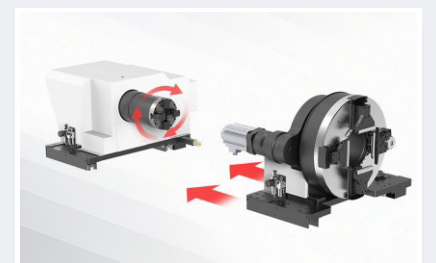

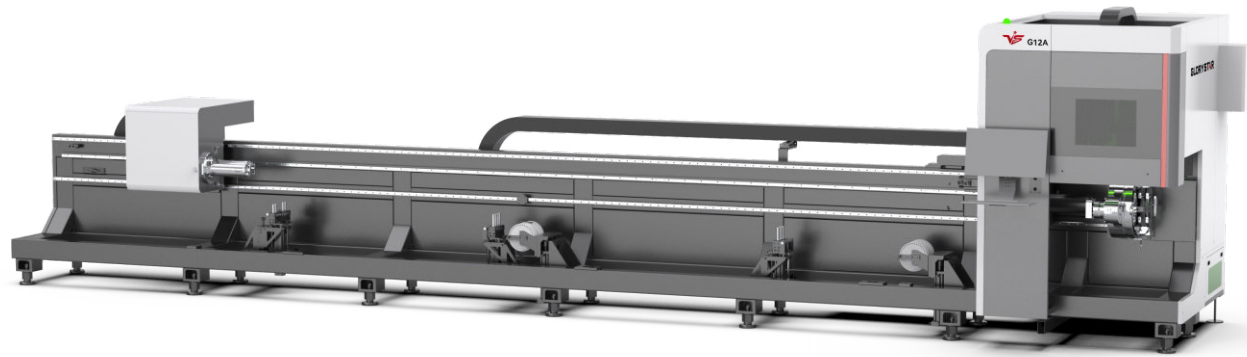

G-A Series

HIGH SPEED HIGH PRECISION

SMALL TUBE HIGH-SPEED CUTTING MACHINE



TECHNICAL SPECIFICATIONS

Model	G12A	G16A
Max. Pipe Size	6500mm / 21.3ft	6500mm / 21.3ft
Repeat Positioning Accuracy	≤0.03mm / ≤0.0012in	≤0.03mm / ≤0.0012in
Positioning Accuracy	≤0.05mm / ≤0.002in	≤0.05mm / ≤0.002in
Max. Positioning Speed	80m/min / 262.5ft/min	80m/min / 262.5ft/min
Max. Acceleration	1.5G	1.2G
Max. Chuck Speed	160r/min	130r/min
Pipe Weight	≤120Kg / ≤573.2lbs	≤160Kg / ≤2205lbs
Machine Weight	3T / 6614lbs	3T / 6614lbs
Machine Footprint	9500×2000mm / 31.2×8ft	9500×2000mm / 31.2×8ft
Power Input	380VAC, 50Hz	380VAC, 50Hz
Round Pipe Processing Range	Φ10mm-Φ120mm / Φ0.4in-Φ4.7in	Φ10mm-Φ160mm / Φ0.8in-Φ6.3in
Square Pipe Processing Range	10×10mm-120×120mm / 0.4×0.4in-4.7×4.7in	10×10mm - 160×160mm / 0.8×0.8in-6.3×6.3in
I-Beam Processing Range	5-8# (50x37mm-80x50mm / 2x1.5in-3.2x2in)	10-12.6# (100x68mm-126x74mm / 3.9x2.8in-4.7x2.9in)

PRECISION CHUCK FOR SMALL TUBES

Equipped with a high-precision cutting chuck specifically designed for small tubes, this enclosed structure offers excellent dust resistance. With clamping accuracy controlled within ±0.1mm, it ensures high stability and reliability while maintaining strong adaptability. It supports secure clamping of non-enclosed profiles such as channel steel, angle iron, and I-beams—enabling precise and efficient processing of complex work spaces.

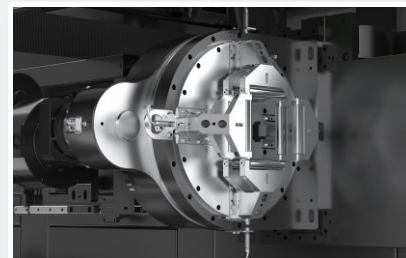

60/80MM ULTRA-SHORT TAILINGS

The innovation supports the forward movement of the chuck and the offside function of the cutting head, enabling precise cutting of long work pieces. The shortest length of the tail material reaches 60mm/80mm, significantly improving the material utilization rate and effectively reducing the waste of tail material. It is particularly suitable for the precision processing scenarios of high-value pipes and greatly reduces production costs.



HIGH-RIGIDITY BED WITH STABLE STRUCTURE AND NO DEFORMATION

The machine adopts a high-strength cage-type welded bed structure, processed by gantry milling and high-temperature annealing. This dual treatment effectively eliminates internal stress and material defects, significantly enhancing the structure's resistance to vibration, torsion, and deformation. Its stability far surpasses that of standard beds, greatly extending machine life and ensuring reliable performance under long-term high-intensity operation.



INTERNAL DUST REMOVAL SYSTEM / EFFICIENT AND ECO-FRIENDLY

Featuring a hollow rear chuck dust extraction design, the system removes fumes directly inside the tube to prevent dust leakage and environmental contamination. The extraction efficiency increases by up to 80%, fully complying with environmental regulations while providing a cleaner, safer workshop environment—empowering manufacturers in their green production transformation.

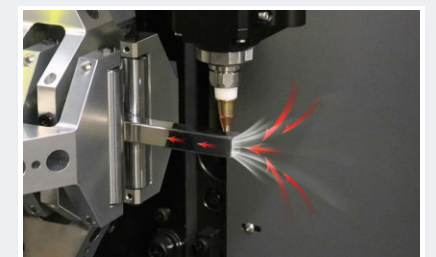



G-PRO Series **HIGH SPEED** **BEVEL CUTTING**

HIGH-SPEED BEVEL CUTTING MACHINE FOR SMALL TUBES



TECHNICAL SPECIFICATIONS

Model	G12 PRO	G16 PRO
Max. Pipe Size	6500mm / 21.3ft	6500mm / 21.3ft
Repeat Positioning Accuracy	≤0.03mm / ≤0.0012in	≤0.03mm / ≤0.0012in
Positioning Accuracy	≤0.05mm / ≤0.002in	≤0.05mm / ≤0.002in
Max. Positioning Speed	80m/min / 262.5ft/min	80m/min / 262.5ft/min
Max. Acceleration	1.5G	1.2G
Max. Chuck Speed	160r/min	130r/min
Pipe Weight	≤120Kg / ≤573.2lbs	≤160Kg / ≤2205lbs
Machine Weight	3.8T / 8378lbs	3.8T / 8378lbs
Machine Footprint	9500×2500mm / 31.2×8.2ft	9500×2500mm / 31.2×8.2ft
Power Input	380VAC, 50Hz	380VAC, 50Hz
Round Pipe Processing Range	Φ10mm-Φ120mm / Φ0.4in-Φ4.7in	Φ10mm-Φ160mm / Φ0.8in-Φ6.3in
Square Pipe Processing Range	10×10mm-120×120mm / 0.4×0.4in-4.7×4.7in	10×10mm - 160×160mm / 0.8×0.8in-6.3×6.3in
I-Beam Processing Range	5-8# (50x37mm~80x50mm / 2x1.5in~3.2x2in)	10-12.6# (100x68mm~126x74mm / 3.9x2.8in~4.7x2.9in)

BEVEL CUTTING / INDUSTRY BENCHMARK

Equipped with an integrated zero-angle oscillating cutting head, this machine supports ±45° multi-angle bevel cutting. Combined with a specially optimized swing arm structure, it not only enhances angular control precision compared to traditional cutting heads but also achieves high-speed, high-stability, intelligent bevel processing without the need to move the tube back and forth. It handles both complex parts and batch processing with ease.

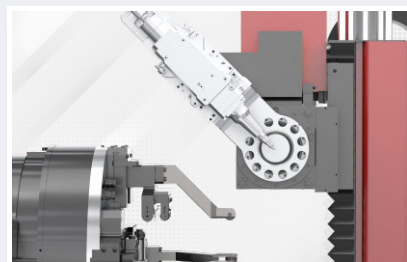

DEDICATED CHUCK / HIGH-PRECISION CUTTING

A dual-chuck system paired with extended jaws is specifically designed for small-diameter tubes, ensuring clamping stability and enabling high-precision bevel cutting for tubes as small as 10mm. The cutting surface is burr-free and slag-free, with high smoothness—ideal for direct splicing or welding without extra grinding or secondary processing, greatly improving overall process efficiency and quality.

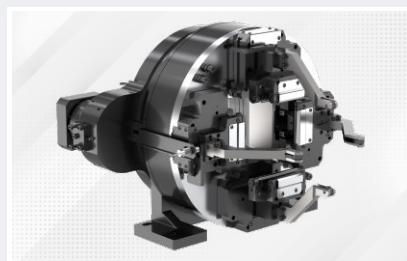

80/160MM SHORT TAILINGS / MAXIMUM MATERIAL SAVINGS

By utilizing the offside function of the cutting head and coordinated motion of the dual chucks, the machine achieves precise cutting between the two chucks with tailing lengths as short as 80mm or 160mm. This dramatically improves material utilization and reduces waste, making it an ideal solution for high-volume manufacturing where cost control is critical.



INTERNAL DUST REMOVAL / ADVANCED UPGRADE

"The machine features high-precision chucks for small tubes, with ±0.1mm clamping accuracy, compatible with profiles like channel steel, angle iron, and I-beams. Its advanced multi-axis dust protection and integrated extraction system remove over 80% of dust, meeting environmental standards and enhancing workspace sustainability.

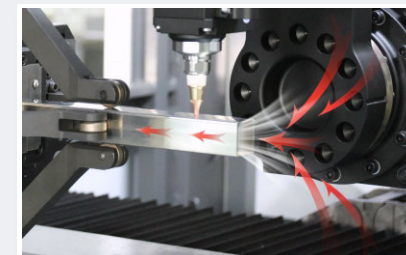



GB Series

CNC HYDRAULIC BENDING MACHINE



TECHNICAL SPECIFICATIONS

Model	GB-10032	GB-16032	GB-16041	GB-20032	GB-20041	GB-25032
Nominal Force (kN)	1000	1600	1600	2000	2000	2500
Working Table Length (mm)	3200 / 10.5ft	3200 / 10.5ft	4100 / 13.5ft	3200 / 10.5ft	4100 / 13.5ft	3200 / 10.5ft
Distance Between Columns (mm)	2700 / 8.9ft	2700 / 8.9ft	3600 / 11.8ft	2700 / 8.9ft	3600 / 11.8ft	2700 / 8.9ft
Max Open Height (mm)	460 / 1.5ft	460 / 1.5ft	460 / 1.5ft	500 / 1.6ft	500 / 1.6ft	500 / 1.6ft
Ram Stroke (mm)	200 / 0.7ft	200 / 0.7ft	200 / 0.7ft	240 / 0.8ft	240 / 0.8ft	240 / 0.8ft
Throat Depth (mm)	400 / 1.3ft	400 / 1.3ft	400 / 1.3ft	400 / 1.3ft	400 / 1.3ft	400 / 1.3ft
X-axis Travel (mm)	650 / 2.1ft	650 / 2.1ft	650 / 2.1ft	650 / 2.1ft	650 / 2.1ft	650 / 2.1ft
R-axis Travel (mm)	150 / 0.5ft	150 / 0.5ft	150 / 0.5ft	150 / 0.5ft	150 / 0.5ft	150 / 0.5ft
Ram Speed (mm/s)	Approach Speed	180 / 0.6ft	160 / 0.5ft	160 / 0.5ft	120 / 0.4ft	110 / 0.4ft
	Bending Speed	10 / 0.4in	9 / 0.4in	9 / 0.4in	8 / 0.3in	8 / 0.3in
	Return Speed	150 / 0.5ft	130 / 0.4ft	130 / 0.4ft	100 / 0.3ft	90 / 0.3ft
Main Motor (kW)	7.5	11	11	15	15	15
Oil Tank Capacity (L)	350	380	480	480	480	480
Weight (kg)	8300 / 18301lbs	10000 / 22046lbs	11500 / 25353lbs	12000 / 26455lbs	13500 / 29762lbs	13000 / 28660lbs
Overall Dimensions (mm)	3400*1990*2580 11.1*6.5*8.5ft	3400*2035*2700 11.1*6.7*8.9ft	4300*2035*2700 14.1*6.7*8.9ft	3400*2165*2810 11.1*7.1*9.2ft	4300*2165*2810 14.1*7.1*9.2ft	3400*2175*2865 11.1*7.1*9.4ft

Model	GB-25041	GB-32032	GB-32041	GB-40041	GB-40061
Nominal Force (kN)	2500	3200	3200	4000	4000
Working Table Length (mm)	4100 / 13.5ft	3200 / 10.5ft	4100 / 13.5ft	4100 / 13.5ft	6100 / 20ft
Distance Between Columns (mm)	3600 / 11.8ft	2700 / 8.9ft	3600 / 11.8ft	3300 / 10.8ft	5000 / 16.4ft
Max Open Height (mm)	500 / 1.6ft	530 / 1.7ft	530 / 1.7ft	530 / 1.7ft	530 / 1.7ft
Ram Stroke (mm)	240 / 0.8ft	240 / 0.8ft	240 / 0.8ft	240 / 0.8ft	240 / 0.8ft
Throat Depth (mm)	400 / 1.3ft	420 / 1.4ft	420 / 1.4ft	430 / 1.4ft	430 / 1.4ft
X-axis Travel (mm)	650 / 2.1ft	650 / 2.1ft	650 / 2.1ft	650 / 2.1ft	650 / 2.1ft
R-axis Travel (mm)	150 / 0.5ft	150 / 0.5ft	150 / 0.5ft	150 / 0.5ft	150 / 0.5ft
Ram Speed (mm/s)	Approach Speed	110 / 0.4ft	100 / 0.3ft	100 / 0.3ft	80 / 0.2ft
	Bending Speed	8 / 0.3in	8 / 0.3in	8 / 0.3in	8 / 0.3in
	Return Speed	90 / 0.3ft	80 / 0.2ft	80 / 0.2ft	70 / 0.2ft
Main Motor (kW)	15	22	22	30	30
Oil Tank Capacity (L)	480	480	600	1000	1000
Weight (kg)	14500 / 31967lbs	15500 / 34171lbs	18000 / 39683lbs	23000 / 50706lbs	32000 / 70548lbs
Overall Dimensions (mm)	4300*2175*2865 14.1*7.1*9.4ft	3400*2320*3050 11.1*7.6*10ft	4300*2320*3250 14.1*7.6*10.7ft	4300*2335*3420 14.1*7.7*11.2ft	6300*2485*3620 20.7*8.1*11.9ft

TOP-TIER CNC SYSTEM, EASY TO OPERATE

Equipped with a top-tier CNC system with powerful features and an intuitive interface that reduces the learning curve and improves production efficiency.



EU-GRADE LINEAR SCALE, HIGH-PRECISION BENDING

Fitted with an EU-standard linear scale with 0.005mm resolution, ensuring precise bending and accurate angles to meet high-standard processing requirements.



GERMAN HYDRAULIC SYSTEM, STABLE AND EFFICIENT

Uses a professional German hydraulic system with high response frequency and stable performance, delivering reliable power even in complex conditions for continuous efficient production.



STANDARD MECHANICAL DEFLECTION COMPENSATION

Equipped with a standard deflection compensation system that adjusts the V-axis in real time to ensure parallelism and straightness of the material, improving precision and quality.

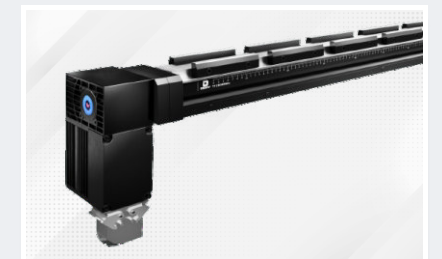

GB-A Series

FULLY AUTOMATIC HIGH-SPEED BENDING CENTER



TECHNICAL SPECIFICATIONS

Model		GB-1200A	GB-1500A	GB-2000A	GB-2500A
Bending Length		1200mm / 4ft	1500mm / 5ft	2000mm / 7ft	2500mm / 8ft
Bending Height		4 sides 170mm 6.69in	4 sides 170mm / 6.7in 2 sides 170mm(6.7in) / 2 sides 350mm(13.8in) 4 sides 350mm / 13.8in		
Max. Bending Size		1200*1200mm 4*4ft	1500*1500mm 5*5ft	2000*1500mm 7*5ft	2500*1500mm 8*5ft
Max. Bending Thickness		2mm / 0.08in	3mm / 0.12in	3mm / 0.12in	3mm / 0.12in
Max. thickness of iron plate		1.5mm / 0.06in	2mm / 0.08in	2mm / 0.08in	2mm / 0.08in
Max. thickness of stainless steel		0.8mm / 0.03in	1.5mm / 0.06in	1.5mm / 0.06in	1.5mm / 0.06in
Maximum Bending Speed		0.2s/per bend	0.2s/per bend	0.2s/per bend	0.2s/per bend
Dimensions	4 sides 170	1590*2950*2666mm 5*10*9ft	1890*3300*2666mm 6*11*9ft	2390*3900*2800mm 8*13*9ft	2890*4500*2800mm 9*15*9ft
	2-4 sides 350 Vacuum Cup	/	1890*3536*2946mm 6*12*10ft	2360*4110*2936mm 8*13*10ft	2900*4460*2936mm 10*15*10ft
	2-4 sides 350 Press Arm	/	1890*4127*2946mm 6*14*10ft	2360*4500*2946mm 8*15*10ft	2880*4950*3090mm 9*16*10ft
Weight	4 sides 170	8000kg 17637lbs	10000kg 22046.3lbs	14000kg 30864.8lbs	17000kg 37478.6lbs
	2-4 sides 350 Vacuum Cup	/	10000kg 22046.3lbs	14000kg 30864.8lbs	17000kg 37478.6lbs
	2-4 sides 350 Press Arm	/	10000kg 22046.3lbs	14000kg 30864.8lbs	17000kg 37478.6lbs

CUSTOMIZED HIGH-PRECISION REDUCER

Equipped with a customized high-precision reducer with accuracy up to 20 arc-seconds, ensuring stable and precise machine operation for precision bending processing.

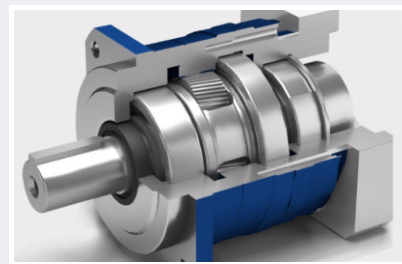

HIGH-PERFORMANCE ABSOLUTE SERVO MOTOR

Equipped with high-performance absolute servo motor, it provides strong power output, quick response, safe and reliable operation, and meets the needs of efficient production.



HIGH-QUALITY THICK STEEL MACHINE BED

Welded with high-quality thick steel plates, optimized through finite element analysis and annealed for durability, offering high precision, minimal deformation, high strength, and rigidity for long-term stable operation.

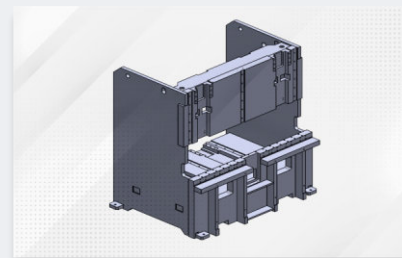

INDEPENDENTLY DEVELOPED CNC SYSTEM

Equipped with GLORYSTAR's self-developed SL300-PCx CNC system for bending centers. The intuitive interface, simple operation, powerful functions, and stable performance enhance production efficiency.

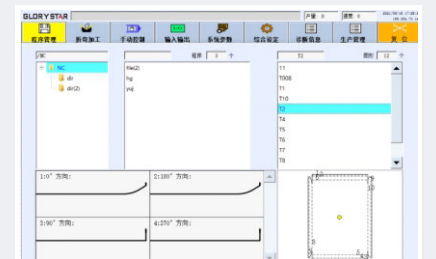

TECHNICAL SPECIFICATIONS

Model	GB-1306E	GB-3512E	GB-4016E	GB-6025E	GB-10032E	
Nominal Pressure	130KN	350KN	400KN	600KN	1000KN	
Bending Length	670mm / 2.2ft	1200mm / 4ft	1600mm / 5ft	2500mm / 8ft	3200mm / 11ft	
Distance Between Columns	620mm / 24.4in	950mm / 37.4in	1320mm / 52in	2020mm / 79.5in	2720mm / 106.3 in	
Max. Ram Open Height	330mm / 13in	430mm / 17in	430mm / 17in	450mm / 17.7in	450mm / 17.7 in	
Ram Stroke	160mm / 6.3in	180mm / 7.1in	180mm / 7.1in	200mm / 7.9in	200mm / 7.9 in	
Throat Depth	210mm / 8.3in	400mm / 15.7in	400mm / 15.7in	360mm / 14.2in	360mm / 14.2 in	
X-axis Travel	400mm / 15.7in	400mm / 15.7in	400mm / 15.7in	600mm / 23.6in	600mm / 23.6 in	
X-axis Speed	400mm / 15.7in/s	400mm / 15.7in/s	400mm/s / 15.7in/s	500mm/s / 19.7in/s	500mm/s / 19.7 in/s	
R-axis Travel	120mm / 4.7in	140mm / 5.5in	140mm / 5.5in	200mm / 7.9in	200mm / 7.9in	
R-axis Speed	200mm / 7.9in/s	200mm / 7.9in/s	200mm/s / 7.9in/s	200mm/s / 7.9in/s	200mm/s / 7.9in/s	
Z-axis Travel	-	700mm / 27.6in	140mm / 41in	1800mm / 70.9in	2500mm / 98.4in	
Z-axis Speed	-	400mm / 15.7in/s	400mm/s / 15.7in/s	400mm/s / 15.7in/s	400mm/s / 15.7in/s	
Slider Speed	Fast Down Ram Speed	200mm/s / 7.9in/s	200mm/s / 7.9in/s	200mm/s / 7.9in/s	180mm/s / 7.1in/s	180mm/s / 7.1in/s
	Working Speed	50mm/s / 2in/s	50mm/s / 2in/s	50mm/s / 2in/s	50mm/s / 2in/s	50mm/s / 2in/s
	Return Speed	200mm/s / 7.9in/s	200mm/s / 7.9in/s	200mm/s / 7.9in/s	180mm/s / 7.1in/s	180mm/s / 7.1 in/s
Dimension	1050*1265*2060mm 3.4*4.2*6.8ft	1685*1265*2290mm 6*4*8ft	2090*1265*2290mm 7*4*8ft	3215*1605*2655mm 11*5*9ft	3915*1605*2655mm 13*5*9ft	
Machine Weight	1100kg / 2425lbs	2500kg / 5511.6lbs	3500kg / 7716.2lbs	5500kg / 12125.5lbs	8000kg / 17637lbs	

GB-E Series

**ALL-ELECTRIC SERVO
BENDING MACHINE**



HIGH-STRENGTH AND STABLE MACHINE BED

The bed is welded with high-quality thick steel plates. The structure is optimized by finite element analysis. The key parts are specially strengthened and annealed, vibrated and shot blasted. It has the characteristics of high precision, small deformation, high strength and high rigidity, ensuring long-term stable and reliable operation of the equipment.

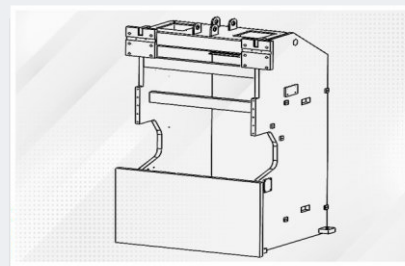

MECHANICAL DEFLECTION COMPENSATION

Equipped with a mechanical deflection compensation workbench with high-precision integral convex lower wave strips and adjustable upper wave strips. The front is equipped with a horizontal fine adjustment mechanism with a dial, which is convenient and intuitive to adjust, ensuring the bending accuracy and consistency of the workpiece.

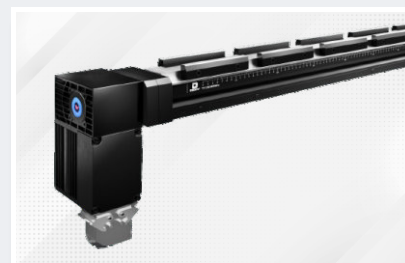

SELF-DEVELOPED CNC SYSTEM

Equipped with the SL100-P CNC system independently developed by GLORystAR, it adopts a high-end development platform and advanced sheet metal bending special algorithms, equipped with a 12-inch LCD touch screen, intuitive interface, simple operation, and easy to use.



FOUR-AXIS BACKGAUGE SYSTEM

The backgauge adopts a 4-axis design, equipped with an AC servo motor and a high-precision reducer. It can be quickly and accurately moved to the required position through the control of the CNC system, and automatically avoids collision with the workpiece during the bending process to improve production efficiency and safety.

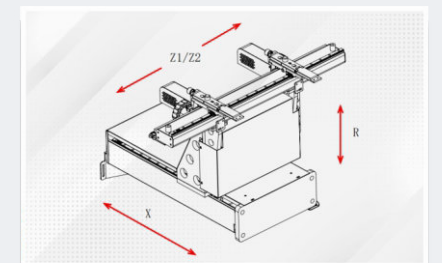

Automated Equipment

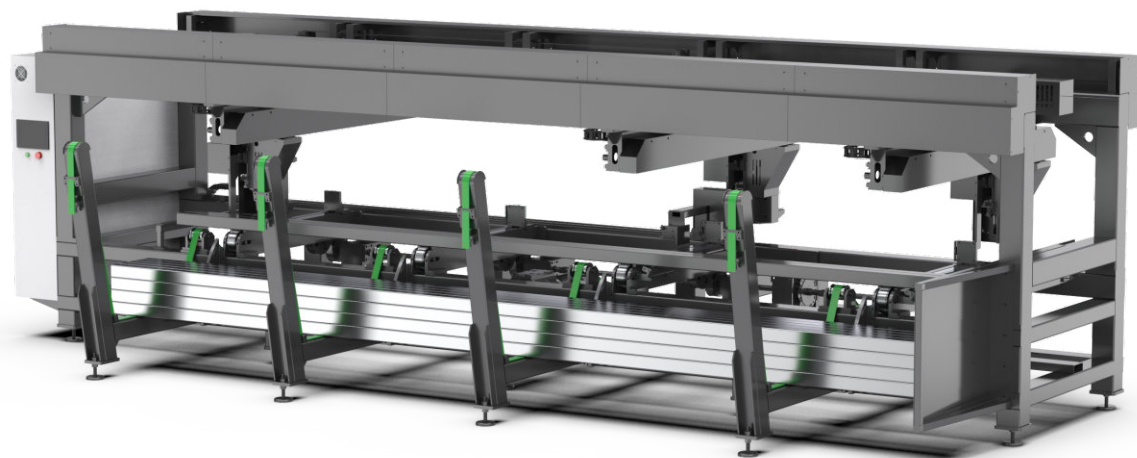

FULLY AUTOMATIC LOADING DEVICE FOR TUBE

- Meet the automated loading requirements for 4-6 meter pipes.
- Reduce labor costs and increase production efficiency.
- Achieve intelligent production and enhance efficiency.

Material Type	Round, square, rectangular tubes, etc.
Feeding Method	Entire bundle hoisting
Feeding Length	4-6m / 13.1-20ft
Max. Weight per Tube	<200kg / <441lbs
Max. Load Capacity	2T / 4410lbs
Rack Dimensions	7600×3600×1600mm / 25×12×5.3ft

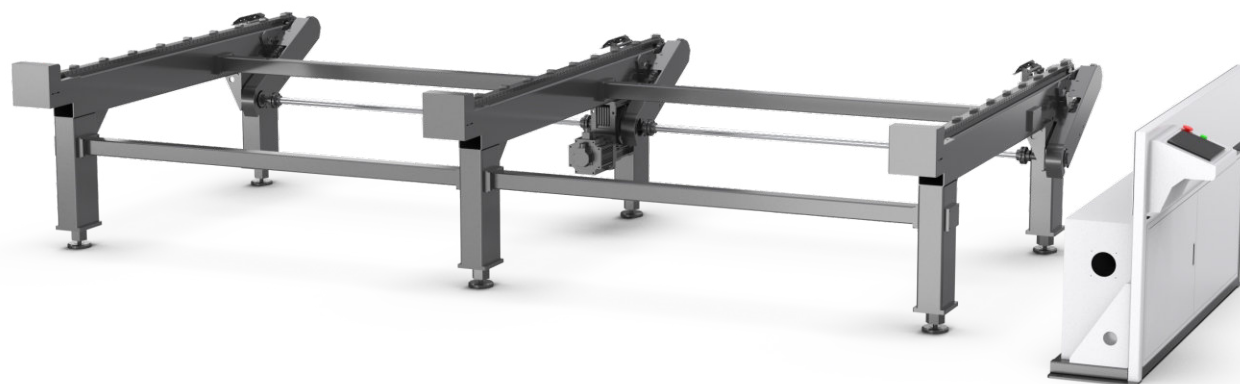

SEMI-AUTOMATIC LOADING DEVICE FOR TUBE

- Meet the automated loading requirements for various types of pipes.
- Reduce labor requirements, save costs, and enhance production efficiency.
- Achieve intelligent production with high efficiency while protecting pipes from scratches.

Material Type	Round tubes, square tubes, channel steel, etc.
Feeding Method	Manual placement
Feed Quantity per Time	6 pieces
Feeding Length	5.6-6.2m / 18.4-20.3ft
Max. Weight per Tube	<120kg / <265lbs
Max. Load Capacity	1T / 2205lbs
Rack Dimensions	5200×2100×950mm / 17.1×6.9×3.1ft

Laser Welding Machine



GW-H Series

WATER-COOLED HANDHELD LASER WELDING MACHINE

- Compact integrated design, flexible and easy to use
- Easy to operate, even inexperienced people can handle it easily
- Fast welding speed with excellent results—one-pass welding without the need for secondary grinding
- Four-in-one: welding, cutting, weld seam cleaning, and Large format cleaning

Model	GW-H
Laser Power	1000-3000W
Adjustable range of light spot	0-5mm / 0-0.20in
Cooling method	Built-in water chiller
Protective Gas	Nitrogen or Argon
Overall Dimensions	1000*650*1100mm / 3*2*4ft



AHW Series

AIR-COOLED HANDHELD LASER WELDING MACHINE

- 3D phase-change cooling technology, suitable for working temperatures from -10°C to 40°C
- Low total power consumption, more energy-efficient than water-cooled models
- Compact design and lightweight welding gun, making it less tiring for operators
- Support continuous operation without interruption

Model	AHW40					AHW30				
Welding thickness	Stainless Steel	Carbon Steel	Galvanized Sheet	Aluminum	Brass	Stainless Steel	Carbon Steel	Galvanized Sheet	Aluminum	Brass
	0.5-4mm 0.02-0.16in	0.5-4mm 0.02-0.16in	0.5-3mm 0.02-0.12in	3mm 0.12in	3mm 0.12in	0.5-3mm 0.02-0.12in	0.5-3mm 0.02-0.12in	0.5-2mm 0.02-0.08in	2mm 0.08in	2mm 0.08in
Spot adjustable range	0-5mm / 0-0.20in					0-5mm / 0-0.20in				
Cooling method	Air cooling					Air Cooling				
Protective gas	Noble gas					Noble gas				
Weight	26kg / 57.32lbs					26kg / 57.32lbs				
Dimensions	250*579*479mm / 1*2*2ft					250*579*479mm / 1*2*2ft				



Auxiliary Equipment



Air Compressor

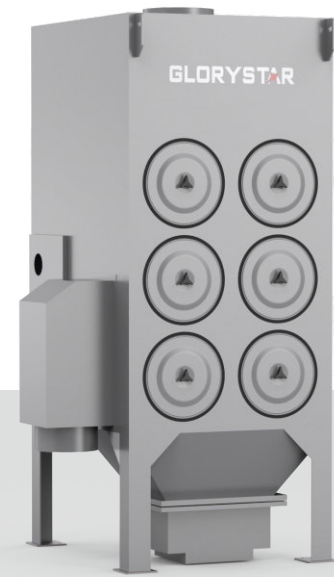

Dust Collector



Water Chiller



Nitrogen Generator