

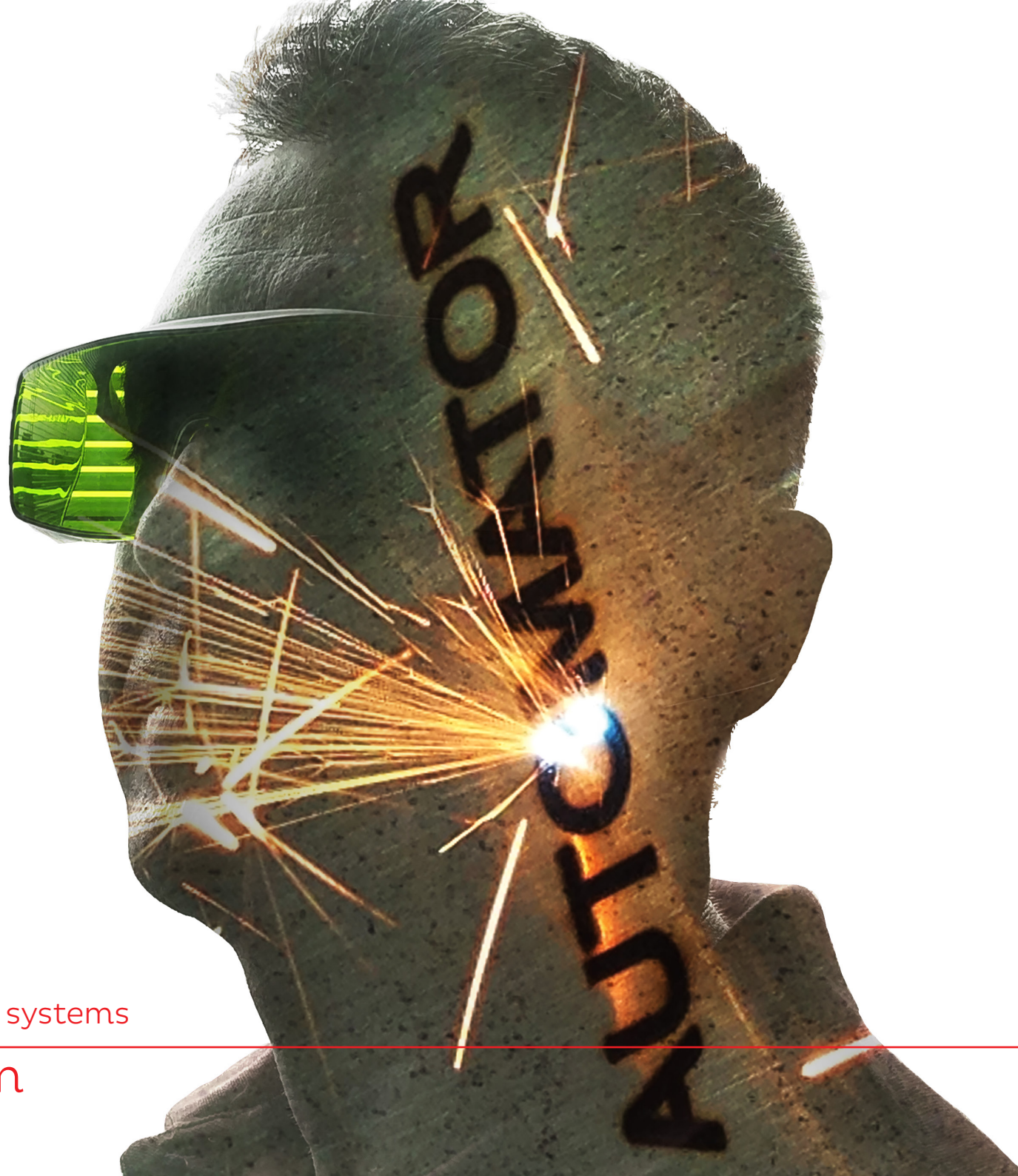

Your Global Marking Partner since 1940



LASER CATALOGUE

Industrial marking machines and systems

www.automator.com

WHY CHOOSE AUTOMATOR?

Since its founding in 1940, AUTOMATOR has been focused exclusively on Industrial Marking Products and Solutions making us the largest manufacturer of marking equipment in the world.

No matter how you want to permanently identify your product, AUTOMATOR has a solution that will exceed your expectation making a mark that will enhance your part and limit your liabilities.

Our GLOBAL network of partners (not just distributors!) are available in 102 countries serving 100+ business sectors. No matter where you are in this world, we are there to support you and our marking products, birth to death.

**We are your global
marking partner
since 1940!**

<http://www.automator.com/us/marketing-technologies-usa>



Laser



Dot peen



Roll stamping



Impact

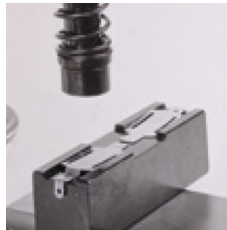

Presses



Scribe

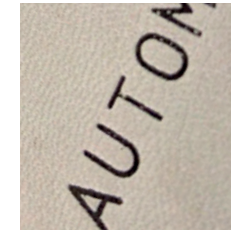

Hot foil

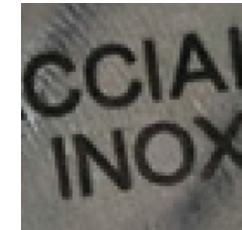

Chem-etch

ALL MATERIALS, ALWAYS THE PERFECT SOLUTION FOR YOUR MARKING NEEDS!

| Power | Source | Class I modelli | Class 4 modelli | Materials |
|---------------------|-------------------------------|---------------------------------------|-----------------|--|
| 2 W | UV @ 355 nm Blue laser | SUPERIOR • OMEGA REX ^{II} | ALPHA | Ceramic • Precious Metals • Plastics • Silicon |
| 3-5-10 W | Green @ 532 nm Green laser | SUPERIOR • ARENA REGINA • OMEGA | VIS | Anodized • Burnished • Metals and Alloys Plastics (not transparent) • Silicon • Painted |
| 10-20-30-40 W | YVO4 @ 1064 nm | SUPERIOR • REGINA ARENA • OMEGA | VIS | Anodized • Burnished • Ceramic • Black Paper • Wood • Metals and Alloys • Leather • Plastics (not transparent) • Polycarbonate • Silicon • Painted |
| 10-20 W | Intra @ 1064 nm | SUPERIOR • ARENA OMEGA | ALPHA | Transparent materials (plastics, glass...) |
| 22-33-54 W | ND:YB @ 1064 nm | ARENA • REGINA SUPERIOR • OMEGA | FYBRA | Anodized • Burnished • Ceramic • Wood • Metals and Alloys • Leather • Plastics (not transparent) • Polycarbonate • Silicon • Painted |
| 10-25-50-100 W | CO2 @ 10640 nm | SUPERIOR • OMEGA REX ^{II} | ALPHA | Anodized • Burnished • Paper • Ceramic • Wood • Plastics • Tissues • Painted • Glass • Organic |
| aWave Technology | YV04 @ 1060 nm | SUPERIOR • ARENA OMEGA • REGINA | nanoVIS | Anodized • Burnished • Metals and Alloys • Plastics (not transparent) • Silicon • Painted • Ceramics |

Automator is certified CISQ,
the consortium for IT Software Quality



Automator Group believes in rational energy use as input
in the design and development of its marking systems



Automator is certified ISO 9001 IQ Net since 2003



Automator Group believes that all its machinery must be
designed and produced according to the concept
of "green philosophy"





aWave
 Revolutionary Automator technology
 for auto-setting of frequency

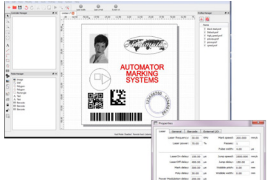

Software EuGENIUS™
 Page 28 for details



Connectivity
 To the PC by USB



Red pointer
 Marking preview



External Power Supply
 24VDC 100/240V 50/60 Hz



Optional FocusFinder
 Focus height automatic
 detection device

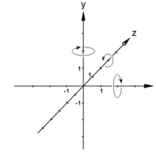
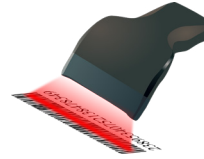

Readers
 Fixed or portable reader for QR codes,
 barcodes and datamatrix (2D codes)

Optional axis
 Z, rotating Theta, up to 32 Axis

Stand alone board
 Marking without PC

Signals PLC digital I/O
 Diagnostics output and check input

Source
 Air cooling



Lenses

| | F100 | F163 | F254 | F330 | F420 |
|---------------|----------|------------|------------|------------|------------|
| Focal lengths | 120 mm | 198 mm | 302 mm | 390 mm | 520 mm |
| Marking Areas | 60x60 mm | 110x110 mm | 155x155 mm | 200x200 mm | 300x300 mm |

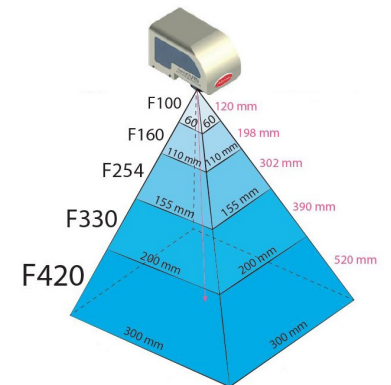

Power 22-33-54 W

FYBRA™

ACTIVE FIBER LASER SYSTEM

NB:Yb 1064 nm

Active fiber marking laser

Designed for a variety of environments, FYBRA generates a high-power laser beam from the source to the head via a flexible fiber optic cable, that allows a considerable increase of the power, without compromising the size of the laser spot. This allows for a better marking result at higher powers and a better efficiency of the system.

Materials

Anodized • Metal • Alloys • Burnished
Ceramics • Ebony • Painted • Plastic
Polycarbonate • Silicon

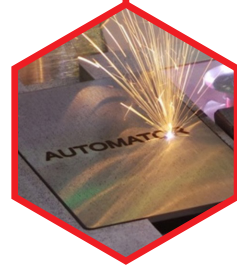



Softwares Genius e Nano
Page 29 for details



Connectivity
To the PC by Ethernet or USB



Red pointer
Marking preview



External Power Supply
24 VDC 100/240 V 50/60 Hz



Optional MOTF
Marking on-the-fly



Optional autofocus
Focal distance between marking head and piece to be marked detection device

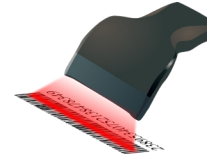

Readers
Fixed or portable reader for QR codes, barcodes and datamatrix

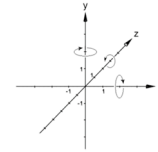

Optional axis
X/Y, Z and rotating Theta

Signals PLC digital I/O
Diagnostics output and check input

Source
Air cooling



Lenses

| | F100 | F163 | F254 | F330 | F420 |
|---------------|----------|------------|------------|------------|------------|
| Focal lengths | 120 mm | 198 mm | 302 mm | 390 mm | 520 mm |
| Marking Areas | 60x60 mm | 110x110 mm | 155x155 mm | 200x200 mm | 300x300 mm |

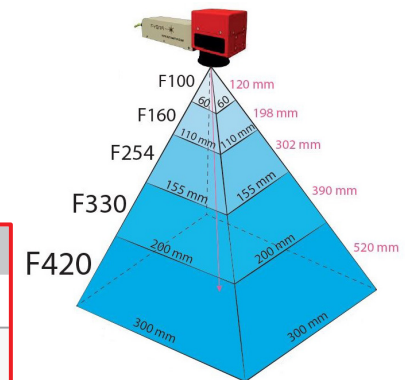

FYBRA™

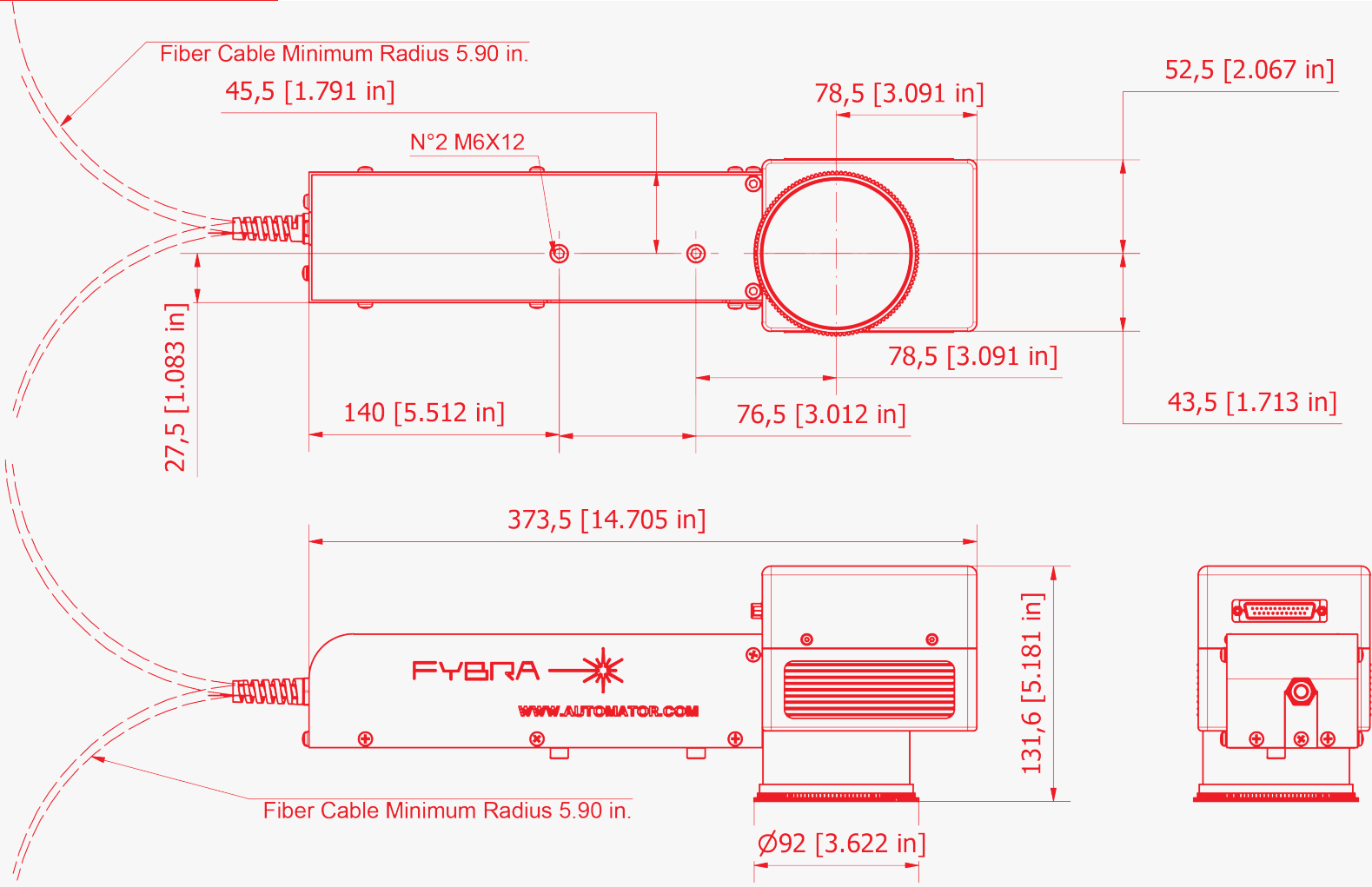

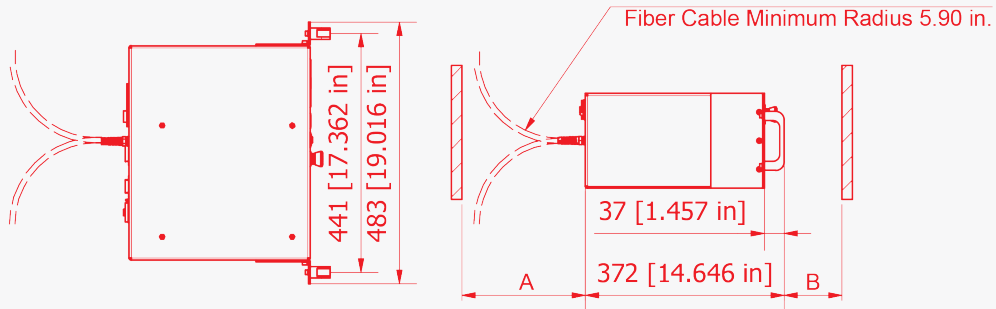

A = 200 mm (7,9 in)
B = 150 mm (5,9 in)

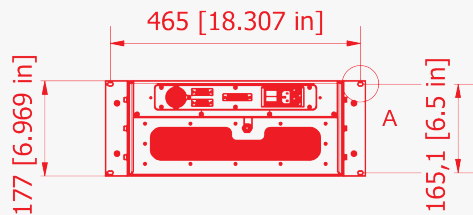
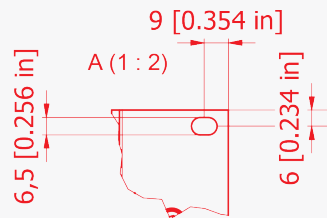

FYBRA 22-33 W

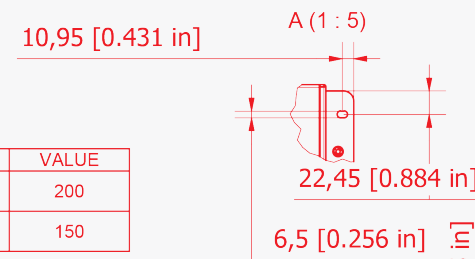
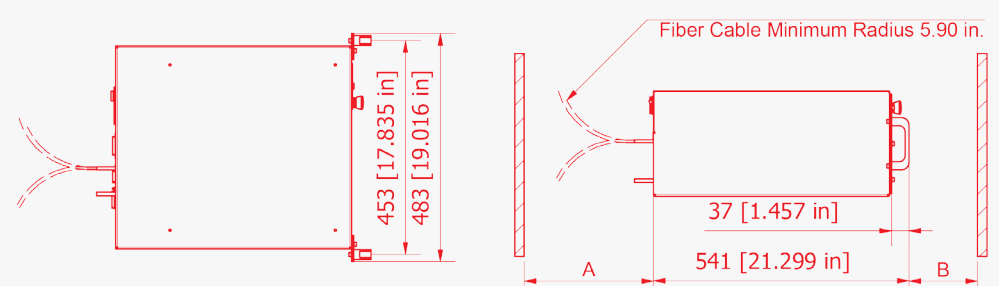

| DATA | VALUE |
|------|-------|
| A | 200 |
| B | 150 |

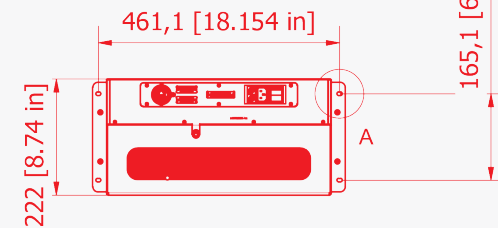

FYBRA 54 W

Power
10-20-30-40 W

VIS™



ALL IN ONE

YVO₄ @1064 nm

YVO₄ source, all in one

Class 4 Yag laser system, extremely light and solid unit "all-in-one", which perfectly adapts to integrations in lines.

Materials

Anodized metal • Alloys • Burnished
Ceramics • Ebony • Painted • Plastic
Polycarbonate • Silicon

<http://www.automator.com/us/marketing-laser-vis>



Watch video now!

<https://vimeo.com/277453922>

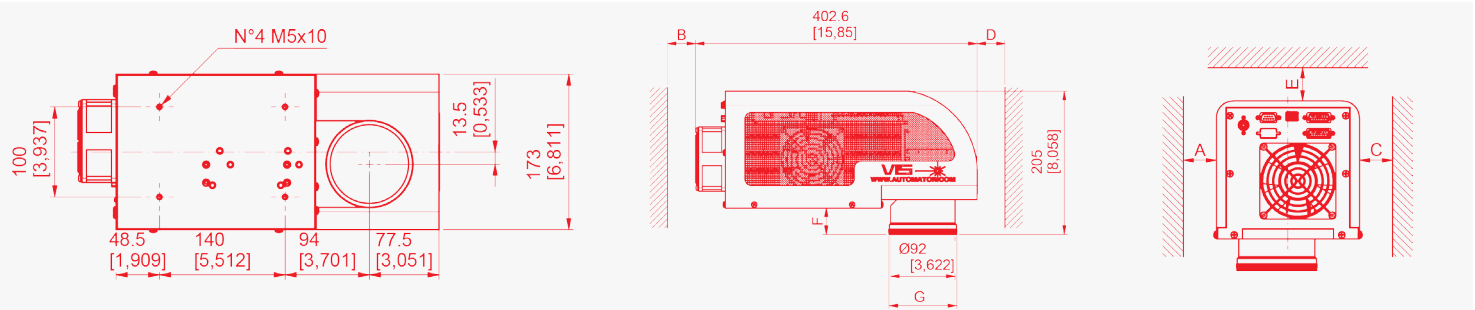



Software Genius
Page 29 for details



Connectivity
Ethernet or Serial



Red pointer
Marking preview



External Power Supply
24 VDC 100/240 V 50/60 Hz



Optional MOTF
Marking on-the-fly



Optional FocusFinder
Focus height automatic detection device

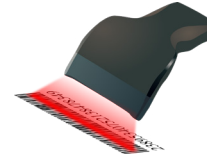

Readers
Fixed or portable reader for QR codes, barcodes and datamatrix

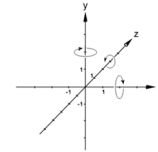

Optional axis
X/Y, Z and rotating Theta



Stand alone board
Marking without PC

Signals PLC digital I/O
Diagnostics output and check input

Source
Air cooling



Lenses

| | F100 | F163 | F254 | F330 | F420 |
|---------------|----------|------------|------------|------------|------------|
| Focal lengths | 120 mm | 198 mm | 302 mm | 390 mm | 520 mm |
| Marking Areas | 60x60 mm | 110x110 mm | 180x180 mm | 220x220 mm | 320x320 mm |

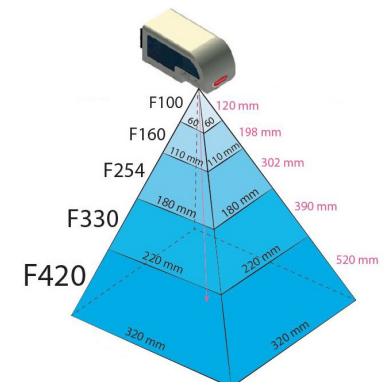

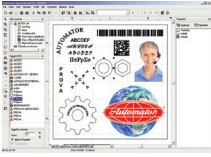

Software Genius
Page 29 for details



Connectivity
Ethernet or Serial



Red pointer
Marking preview



External Power Supply
24 VDC 100/240 V 50/60 Hz



Optional MOTF
Marking on-the-fly



Optional FocusFinder
Focus height automatic detection device

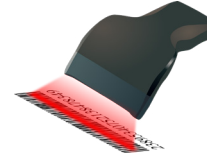

Readers
Fixed or portable reader for QR codes, barcodes and datamatrix

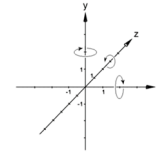

Optional axis
X/Y, Z and rotating Theta



Stand alone board
Marking without PC

Signals PLC digital I/O
Diagnostics output and check input

Source
Air cooling



Lenses

| | F100 | F163 | F254 | F330 | F420 |
|---------------|----------|------------|------------|------------|------------|
| Focal lengths | 120 mm | 198 mm | 302 mm | 390 mm | 520 mm |
| Marking Areas | 60x60 mm | 110x110 mm | 180x180 mm | 220x220 mm | 320x320 mm |

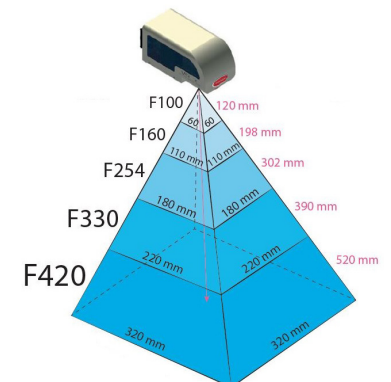

Power
3-5-10-20-30-40 W

VIS-P™

PORTABLE LASER

YVO₄ @1064 nm
 YVO₄ @532 nm green

**The smallest portable
 laser in the world**

Class I Yag laser system, extremely lightweight and compact unit "all-in-one", which perfectly adapts to portable applications.

Materials

Anodized metal • Alloys
 Burnished • Ceramics • Painted
 Plastic • Polycarbonate • Silicon



<http://www.automator.com/us/vis-p-US1>

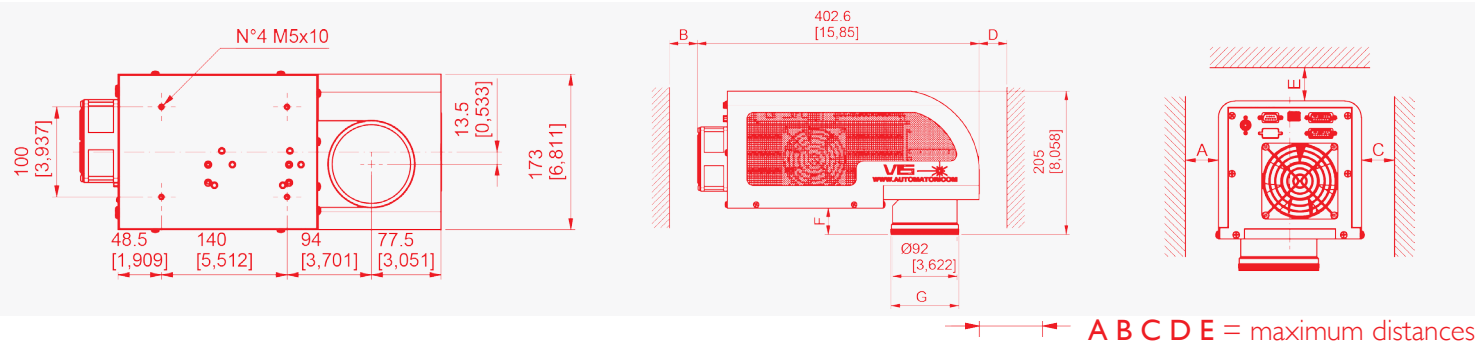



Software Genius
Page 29 for details



Stand alone board
Marking without PC



Connectivity
Ethernet or Serial



Signals PLC digital I/O
Diagnostics output and check input



Red pointer
Marking preview

Portable kit
Handheld structure with adjustable telescopic security system and three supports



External Power Supply
24VDC 100/240V 50/60 Hz

Source
Air cooling



Optional FocusFinder
Focus height automatic detection device

Lenses

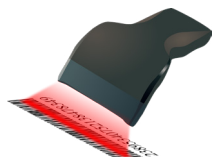

Readers
Fixed or portable reader for QR codes, barcodes and datamatrix

| | F100 | F163 | F330 |
|---------------|----------|------------|------------|
| Focal lengths | 120 mm | 198 mm | 390 mm |
| Marking Areas | 60x60 mm | 110x110 mm | 220x220 mm |

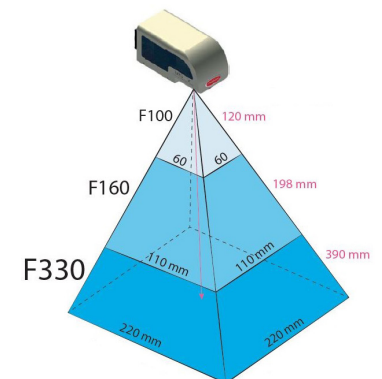

Power
10-25-50-100 W

ALPHA™

LASER CO2
CO2 @10640 nm

Powerful and efficient

Class 4 CO2 laser system, extremely light and solid in two units: laser source and galvanometric head with optical path, and 4-unit cabinet with electric circuit and electronics. Perfect to mark on wood and glass.

Materials

Burnished • Anodized • Alloys
Ceramics • Ebony • Glass • Painted
Paper • Plastic • Polycarbonate
Precious Stones • Rubber • Silicon • Wood





Software Genius
Page 29 for details



Connectivity
To the PC by Ethernet or USB



Red pointer
Marking preview



Optional FocusFinder
Focus height automatic detection device



Optional MOTF
Marking on-the-fly

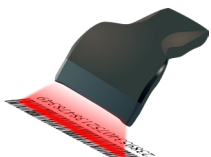

Readers
Fixed or portable reader for QR codes, barcodes and datamatrix



Power Supply
24VDC 100/240V 50/60 Hz



Stand alone board
Marking without PC

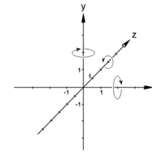

Optional axis
X/Y, Z and rotating Theta

Signals PLC digital I/O
Diagnostics output and check input

Source
Air cooling



Lenses

| | F200 | F100 | F300 | F435 |
|---------------|------------|----------|------------|------------|
| Focal lengths | 230 mm | 100 mm | 350 mm | 550 mm |
| Marking Areas | 140x140 mm | 70x70 mm | 210x210 mm | 300x300 mm |

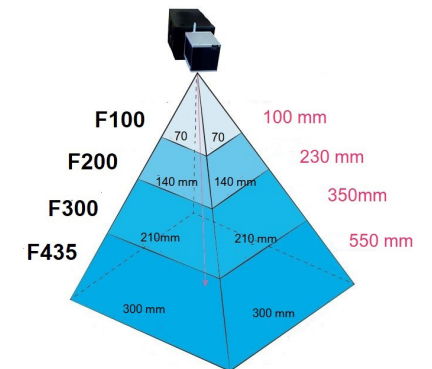

**Loading Area
21,6x17,3"**

<http://www.automator.com/us/laser-marker-arena-us>

ARENA™

For FYBRA, nanoVIS II,
VIS and greenVIS

**COMPACT, ROBUST
AND AUTOMATIC**

**Laser enclosure
in Safety class I**

Laser enclosure with Electro-pneumatic
automatic opening door and
software-driven Z axis.

Materials

Anodized metal • Alloys
Burnished • Ceramics • Ebony • Painted
Plastic • Polycarbonate • Silicon

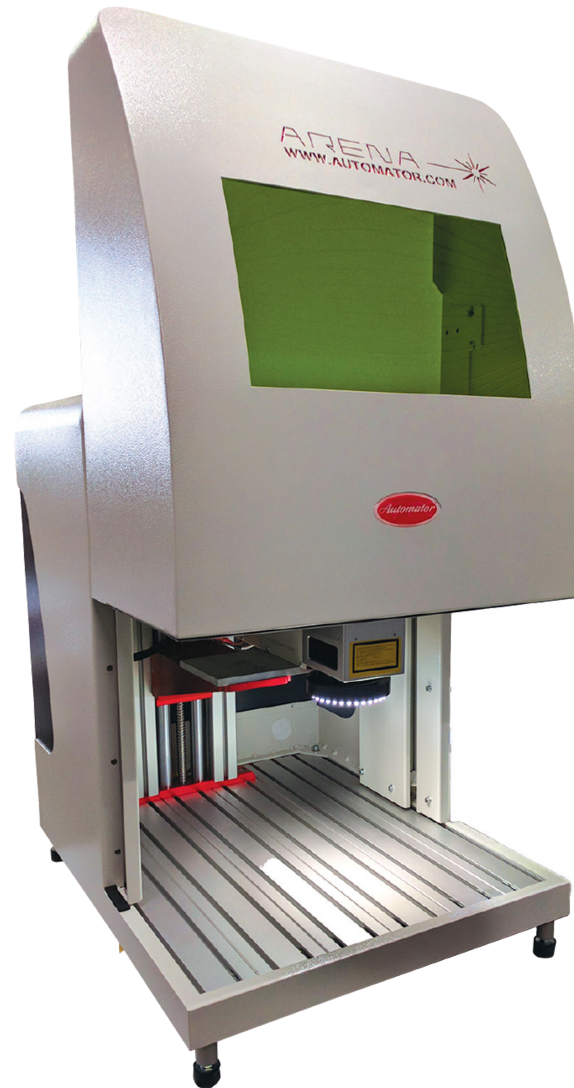

**Arena Workstation
for FYBRA 22-33-54 W**

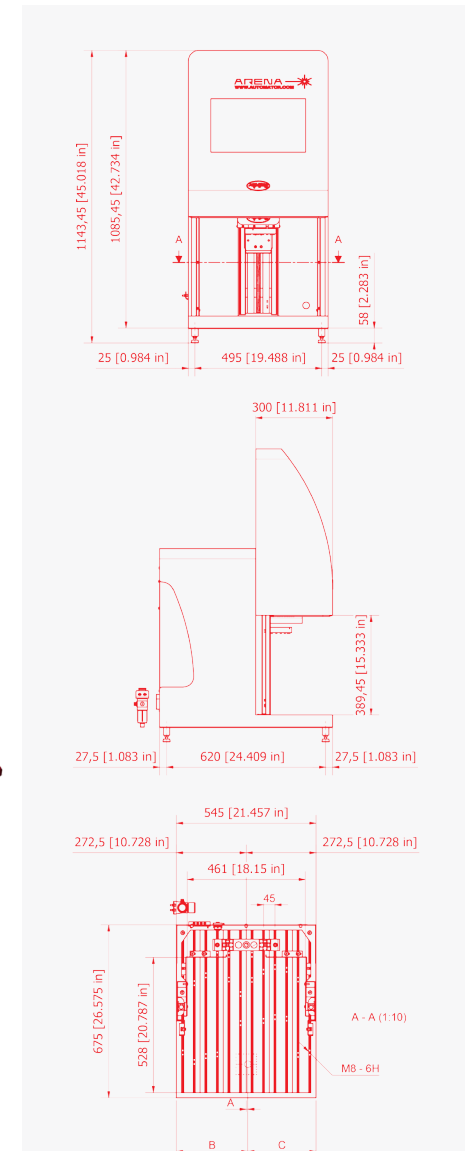



Red pointer
Marking preview



Stand alone board
Marking without PC

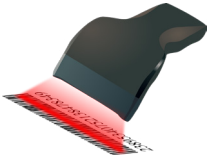

Readers
Fixed or portable reader for
QR codes, barcodes and datamatrix



Optional FocusFinder
Focus height automatic
detection device

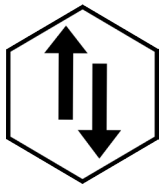

Z Axis
Electric or software-driven,
maximum height 7,9 mm



Optional Theta Axis
Electric, software driven rotary
possible maximum Weight: 11 kg



Console
On the front, with system drive
commands and safety buttons

Inspection window
400x250 mm - 15.7x10"

Loading area
550x440 mm - 21,6x17,3"

Source
Air cooling



Exhaust air connection



Lenses

| Source | F100 | F160 | F254 |
|---|-------|---------|---------|
| Maximum markable object height with FYBRA, nanoVIS, VIS and greenVIS (mm) | 313 | 243 | 139 |
| Marking Area (mm) | 60x60 | 110x110 | 180x180 |

**Loading Area
31,5x31,5"**

REX^{II}™

For FYBRA, nanoVIS II,
VIS and greenVIS

**ROBUST, AUTOMATIC
AND STAND-ALONE
FOR MID & LARGE
SCALE PRODUCTIONS**

**Benchttop laser marking
systems in Safety class I**

Laser marking system with large
loading area, manual door opening,
X/Y/Z axis and SmartMark™ vision system.
Up to 32 available external axis.

Materials

Anodized metal • Alloys
Burnished • Ceramics • Ebony • Painted
Plastic • Polycarbonate • Silicon



<http://www.automator.com/us/rexii-laser-marking-system>

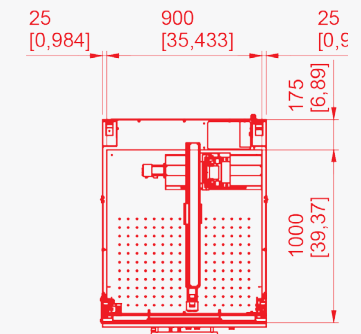
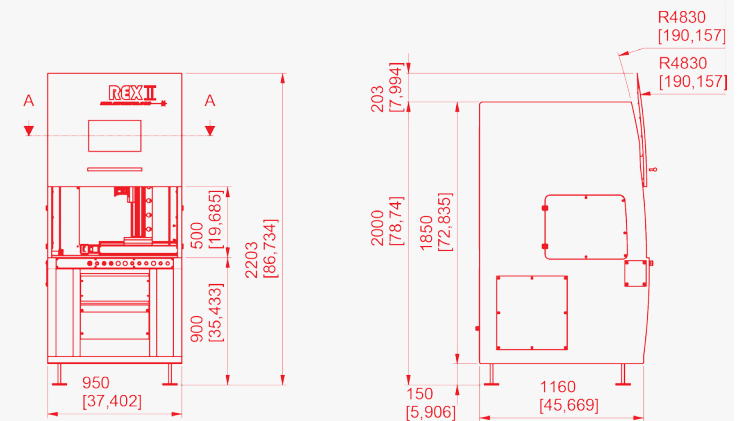

A - A (1 : 28)

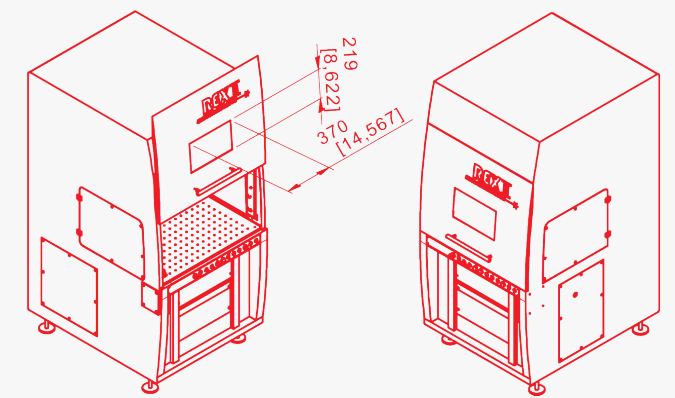



Red pointer
Marking preview



Stand alone board
Marking without PC

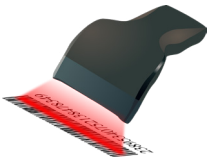

Readers
Fixed or portable reader for
QR codes, barcodes and datamatrix

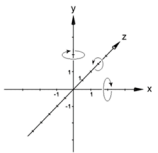

Programmable axis
X/Y,Z standard
Theta, rotary table, up to 32 axis
X= 400 mm (15,7 in)
Y= 300 mm (11,8 in)
Z= 500 mm (19,6 in)

Door opening
Sliding manual opening
Maximum door opening height:
500 mm - 19,68"

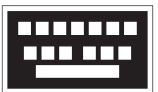

Console
On one side, with system drive
commands and safety buttons.
R/L mounted moving arm and Status bar

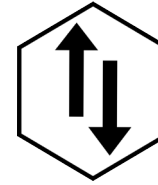

Z Axis
Electric or software-driven

Inspection window
400x250 mm - 15.7x10"

Loading area
1000x900 mm - 39,37x35,43"

Source
Air cooling

Fume extractor
Filtered air volume:
350 cube meter per hour

Standard fume extractor
PURA1 triple filter air purifier



Lenses

| | F100 | F163 | F254 | F330 | F420 |
|---------------|----------|------------|------------|------------|------------|
| Focal lengths | 120 mm | 198 mm | 302 mm | 390 mm | 520 mm |
| Marking Areas | 60x60 mm | 110x110 mm | 155x155 mm | 200x200 mm | 300x300 mm |

Loading Area
15,7x15,7"

REGINA™

<http://www.automator.com/us/laser-marking-system-regina-en-us>

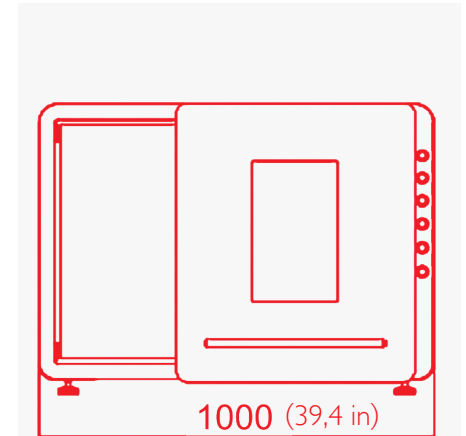
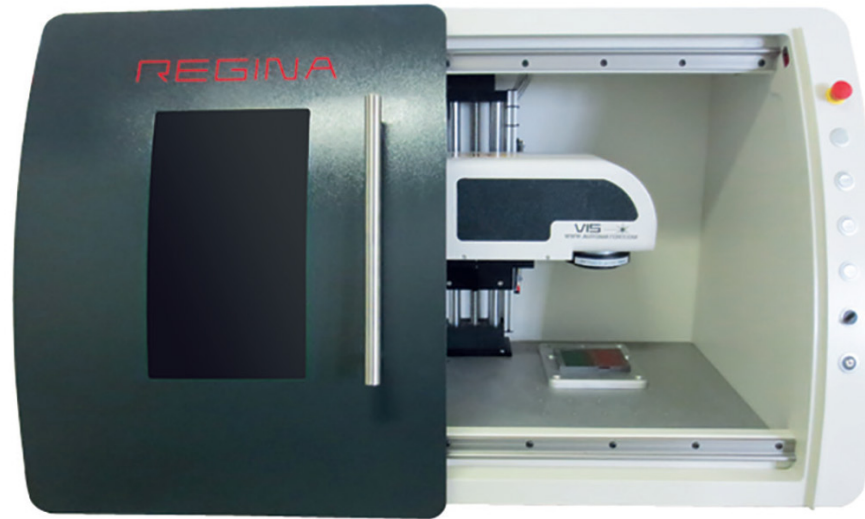

For FYBRA, nanoVIS II,
VIS and greenVIS

**STYLISH AND
PRACTICAL**

**Laser enclosure
in Safety class I**

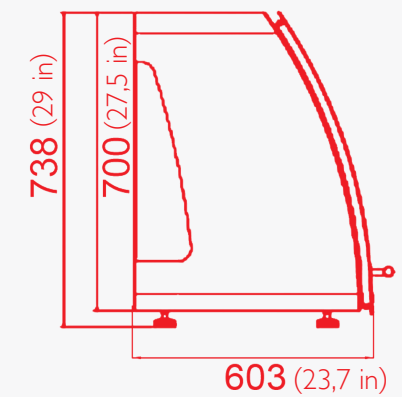

Class I laser enclosure with manual opening
door and electric-automatic Z axis



Red pointer
Marking preview



Stand alone board
Marking without PC

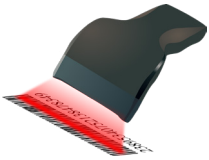

Readers
Fixed or portable reader for QR codes, barcodes and datamatrix



Optional FocusFinder
Focus height automatic detection device

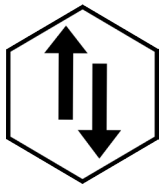

Standard Z Axis
Electric or software-driven, maximum height 7,9 mm



Optional Theta Axis
Electric, software driven rotary axis Weight: 11 kg



Opening door
Sliding manual opening

Console
On the front, with system drive commands and safety buttons

Inspection window
15.7x10"

Loading area
15,7x15,7"

Source
Air cooling



Lenses

| Source | F100 | F160 | F254 |
|--|-------|---------|---------|
| Item maximum height with FYBRA, nanoVIS, VIS and greenVIS (mm) | 300 | 216 | 100 |
| REGINA with ALPHA CO2 (mm) | 300 | 190 | - |
| Marking Area (mm) | 60x60 | 110x110 | 180x180 |

**Loading Area
13,5x13,4"**

OMEGA™

<http://www.automator.com/us/laser-marking-system-omega>

For FYBRA, nanoVIS II,
VIS and greenVIS

**COMFORTABLE
AND RELIABLE**

**Laser enclosure
in Safety class I**

Class I laser enclosure with manual opening door and large protected inspection window. Efficient and cost-effective



Panels can be easily removed to mark larger items.

Hinged door, large inspection window, manual adjustment of the Z axis, available customizations.

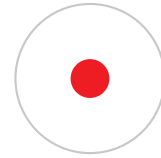
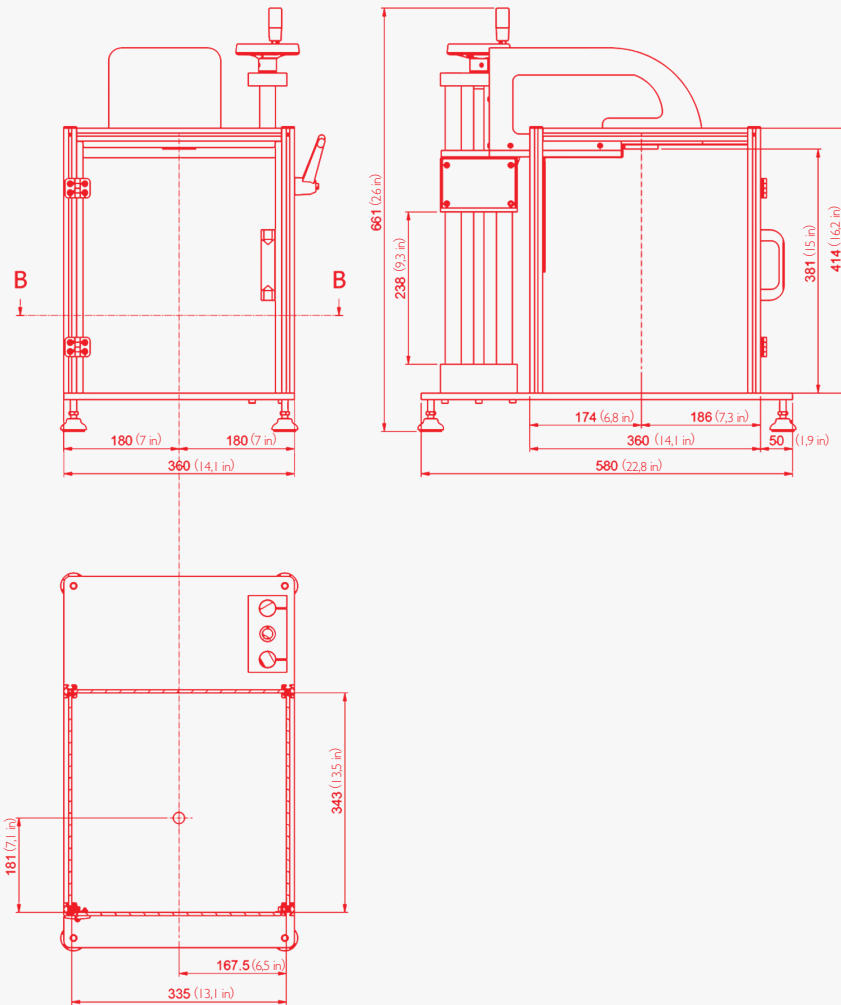

Red pointer
Marking preview

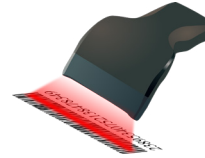

Readers
Fixed or portable reader for QR codes, barcodes and datamatrix



Optional FocusFinder
Focus height automatic detection device

Source
Air cooling

Software
Depending by the laser source



Lenses

| Source | F100 | F160 | F254 |
|--|-------|---------|---------|
| Item maximum height with FYBRA, nanoVIS, VIS and greenVIS (mm) | 200 | 110 | 10 |
| Marking Area (mm) | 60x60 | 110x110 | 180x180 |

**Loading Area
31,5x31,5"**

<http://www.automator.com/us/industrial-marking-laser-superior-us>

SUPERIOR™

For FYBRA, NanoVIS,
VIS and GreenVIS

FOR BIG PRODUCTIONS

Class I laser enclosure
for big productions with
manual opening door and
large protected inspection
window.

Loading area: 31,5"x31,5", with frontal
opening door and protected inspection
window.



**X/Y
optional
axis**

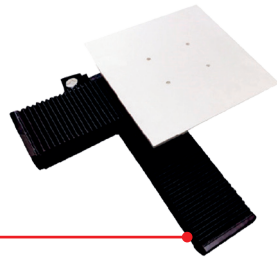

**Optional
Theta
rotary axis**

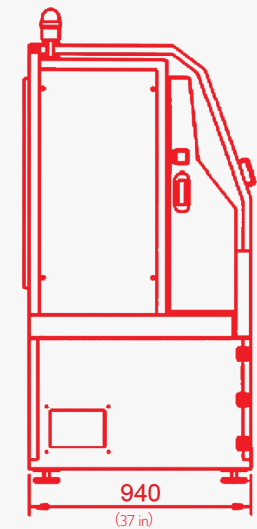
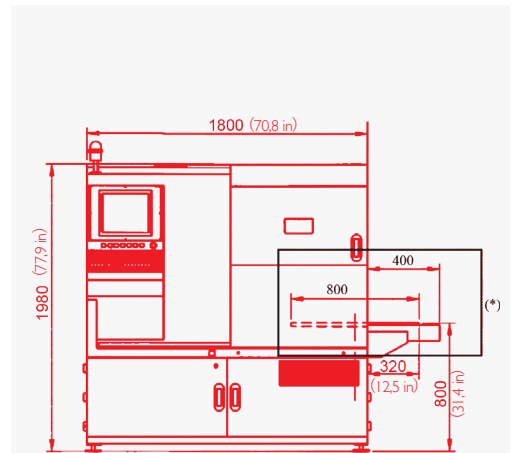
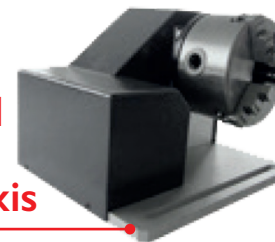



Red pointer
Marking preview



Optional axis
X/Y and rotating Theta



Stand alone board
Marking without PC

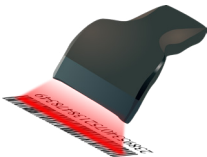

Readers
Fixed or portable reader for
QR codes, barcodes and datamatrix



Optional FocusFinder
Focus height automatic
detection device



Theta Axis
Electric, software driven rotary
axis Weight: 11 kg

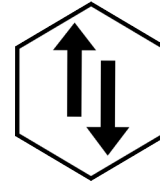

Z Axis
Electric, maximum height, 430 mm (16,9")

Loading area
15,7x15,7"

Lights
System status signals

Source
Air cooling



Lenses

| Source | F100 | F160 | F254 |
|---|-------|---------|---------|
| Item maximum height with FYBRA, nanoVIS, VIS and greenVIS (mm) | 630 | 546 | 430 |
| SUPERIOR with ALPHA CO2 (mm) | 730 | 520 | - |
| Marking Area (mm) | 60x60 | 110x110 | 180x180 |
| With rotary table (mm) | 450 | 370 | 250 |

SOFTWARE

EuGENIUS™

EuGenius Software has been designed and developed by Automator highly specialized team, consolidating the marked requests in the long term marking knowhow of more than 70 years in marking. Versatile in the applications and friendly to use, even by operators without highly technical specific training, such as CAD knowledge.

- Multilanguage menu
- Management barcode "Datamatrix", 2D code, QR code, PDF Queues
- Easy import of vector drawings, DXF
- Easy import of raster graphics, BMP, JPEG, JPG, GIF
- Complete set of laser parameters such as speed or power laser
- Texts, Text arcs, text on curved lines,
- Lines, rectangles, polygons, circles and arcs
- TTF Font ® (windows property)
- Graphic preview
- Texts with date, serial numbers, shift codes and year/month/day
- Multi fillings or single profile markings
- Templates (object to be marked as background)
- Proportion scale, move, rotate, group creation of each object on the screen
- Quick Test for an easy identification of the best laser parameters
- Automation & object tiling
- External axis commanded by software
- Shutter control
- Easy diagnosis of troubleshootings

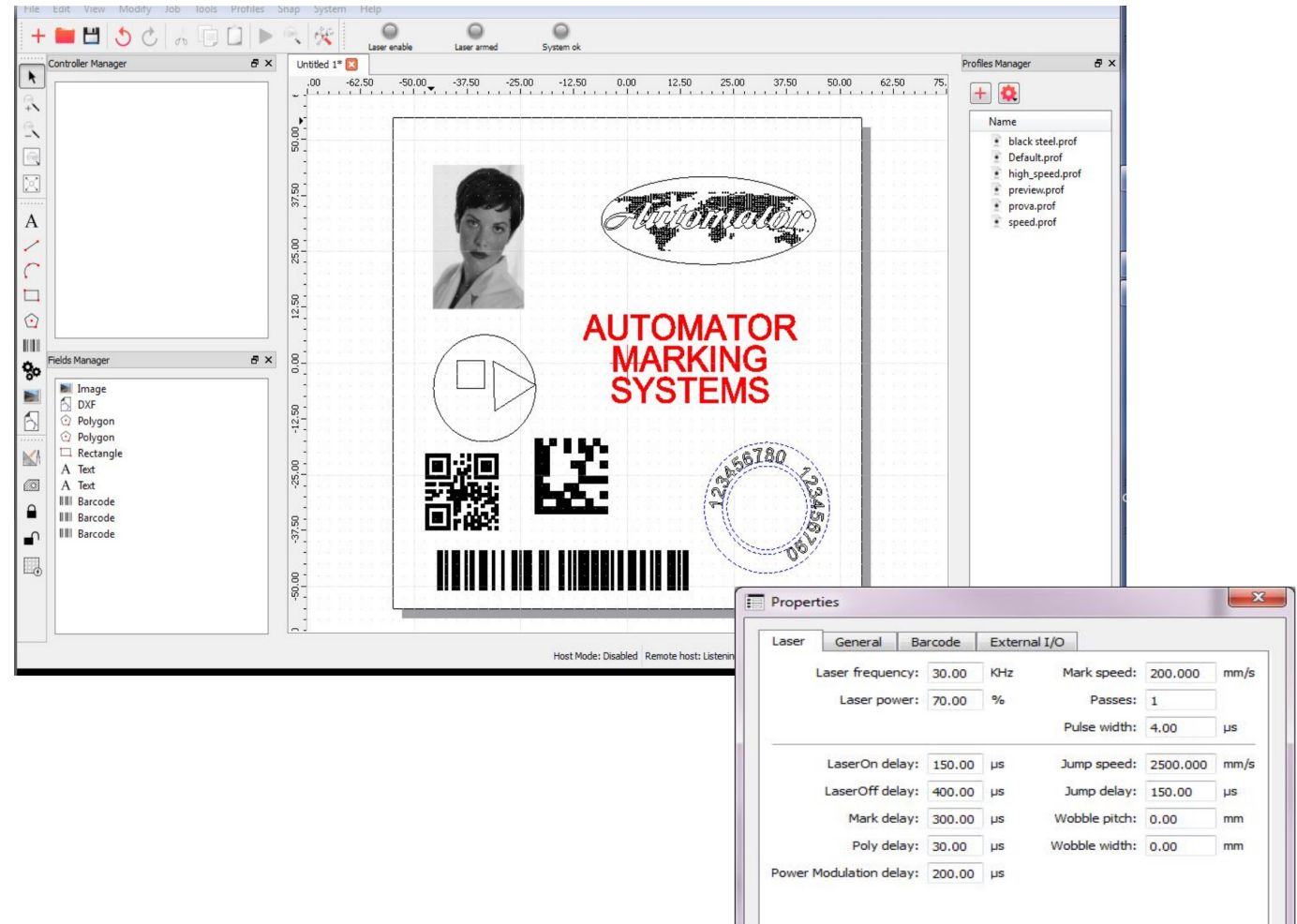

SOFTWARE GENIUS PLUS

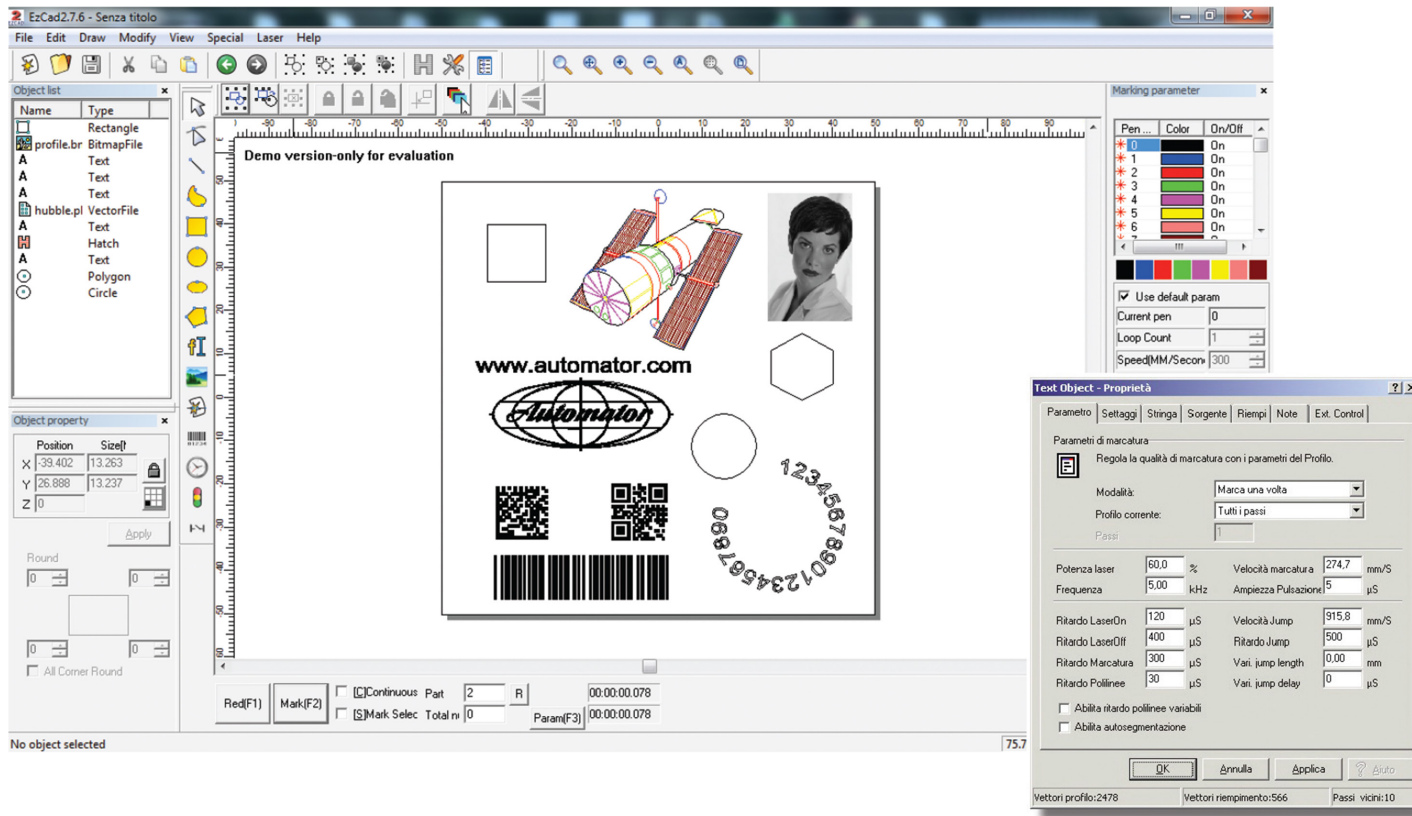

Software versatile in the applications and easy to use, even by operators without CAD knowledge. Three different configurations: BASIC version, STANDARD version and ADVANCED version.

Complete management of the texts and arc texts with TrueType Font full compatibility. Direct management of the basic drawing elements (rectangles, circles, polygons, arcs, etc), management of barcodes (Code 39, codebar, code 93, code 12 EAN / UCC128, interleaved 2 or 5 ITF, postnet, tuple, tuples, EAN 8, EAN 13, booklan), DATAMATRIX (ECC 200) and QR codes, UID / UDI 2D Matrix.

Graphics and photos importable in Raster format (JPG, BMP, PCX, GIF).

Drawings and logos importable in vector format (DXF, DWG, AI, CDR, WMF, PLT, EMF). View and order management for marking objects, as well as ability to control external automations such as X and Y axes, Z axis Theta axis (rotary), delays and signal exchanges with the external environment.

PURA 1™



Filtering system for laser marking dust and fumes

Safe and reliable, internal air quality standards, GB21551.1-2008, GB / T 18801.
Purification rate: 99.97%

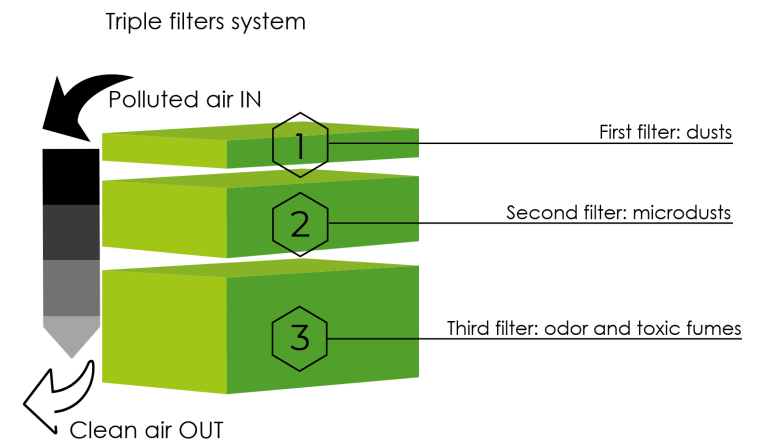



Inlet air interface:
Ø 75 mm



110V 220V
(50 Hz-60Hz) input voltage



80W
rated power



Air flow speed:
12m/s



DC200W
brushless motor power

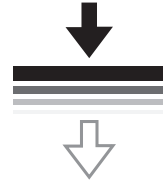

Filtered air volume:
350 cubic meters per hour

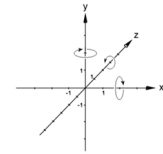

Dimensions:
424x258x440 mm - 16,7x9,8x17,3"



0.3 micron filtering effect
with 99.99% filter

MARKING LASERS COMPARISON

| | Laser sources | | | | | | Enclosures | | | | |
|-------------------------|-----------------------|--------|----------|--------|---------------------|---------------------|------------|----------|---------------------|----------|-------------------|
| | nanoVIS ^{II} | VIS | ALPHA | VIS-P | FYBRA | MOPA | ARENA | REGINA | OMEGA | SUPERIOR | REX ^{II} |
| Class | 4 | 4 | 4 | I | 4 | 4 | I | I | I | I | I |
| Integration | x | x | x | | x | x | | | | | |
| Benchtop | | | | | | | x | x | x | | |
| Large scale productions | | | | | | | | | | x | x |
| Portable | | | | x | | | | | | | |
| Ethernet | | x | x | x | x | x | x | x | Variable | | |
| YVO4 | x | x | x | x | | | x | x | x | x | x |
| CO2 | | | x | | | | x | | x | x | x |
| Green | | x | x | | | | x | x | x | x | x |
| Ytterbium | | | | | x | x | | | | | |
| UV | | | x | | | | | | x | x | x |
| Intra | | | | | | | x | | x | x | x |
| Software | nanoVIS | Genius | EuGENIUS | Genius | Genius/ EuGENIUS | Genius/ EuGENIUS | EuGENIUS | EuGENIUS | Genius/ EuGENIUS | EuGENIUS | EuGENIUS |

| | nanoVIS | VIS | ALPHA | VIS-P | FYBRA | MOPA | ARENA | REGINA | OMEGA | SUPERIOR | REX ^{II} |
|---------------------------|----------|----------|----------|----------|----------|----------|----------|----------|----------|----------|-------------------|
| X/Y | Optional | Optional | Optional | | Optional | Optional | | | | Optional | Optional |
| Theta | Optional | Optional | Optional | | Optional | Optional | Optional | Optional | Optional | Optional | Optional |
| Manual X axis | Optional | Optional | Optional | | Optional | Optional | Optional | Optional | x | Optional | Optional |
| Programmable Z axis | Optional | Optional | Optional | | Optional | Optional | x | x | Optional | x | x |
| Stand Alone (without PC) | | Optional | Optional | | Optional | Optional | Optional | Optional | | Optional | Optional |
| Marking on the fly (MOTF) | | Optional | Optional | Optional | Optional | Optional | | | | | |
| Reader | Optional | Optional | Optional | Optional | Optional | Optional | Optional | Optional | Optional | Optional | Optional |
| Preview | x | x | x | x | x | x | x | x | x | x | x |
| Anodized | x | x | x | x | x | x | x | x | x | x | x |
| Burnished | x | x | x | x | x | x | x | x | x | x | x |
| Ceramics | x | x | x | x | x | x | x | x | x | x | x |
| Ebony | x | x | | x | x | x | x | x | x | x | x |
| Tissues | | | x | | | | x | | x | x | x |
| Glass | | | x | | | | x | | x | x | x |
| Leather | x | | | | | | x | | x | x | x |
| Metals | x | x | x | x | x | x | x | x | x | x | x |
| Painted | x | x | x | x | x | x | x | x | x | x | x |
| Paper | x | | x | | | | x | | x | x | x |
| Plastics | x | x | x | x | x | x | x | x | x | x | x |
| Polycarbonate | x | x | x | x | x | x | x | x | x | x | x |
| Precious | | | x | | | | | | x | x | x |
| Rubber | | | x | | | | x | | x | x | x |
| Silicon | x | x | x | x | x | x | x | x | x | x | x |
| Transparent materials | | | | | | | x | | x | x | x |
| Wood | x | | x | | | | x | | x | x | x |

MARK, READ AND TRACK!

QR code



Data matrix



Barcode

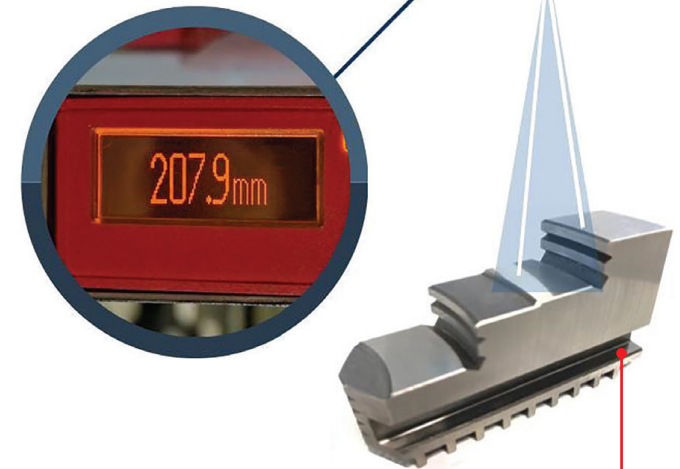

FOCAL DISTANCE FINDER™
Get always focused!



AUTOMATIC



www.automator.com

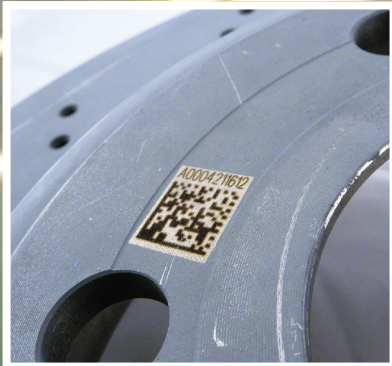
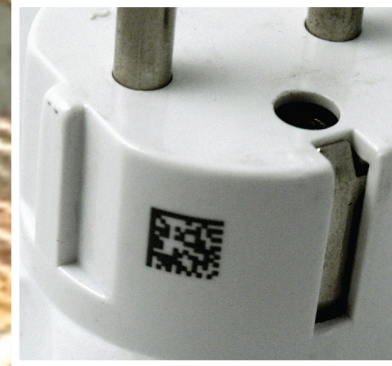
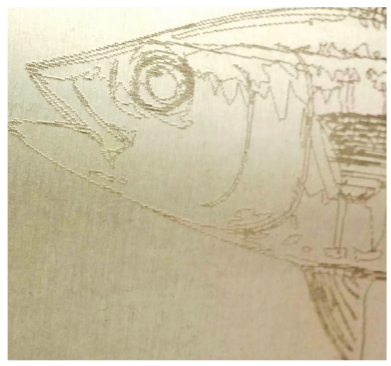

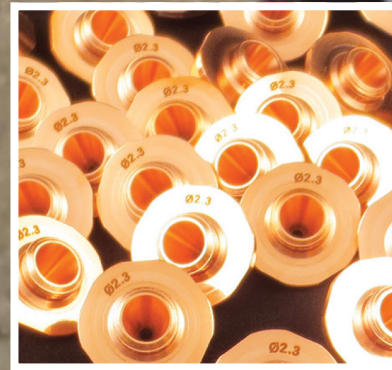



www.automator.com

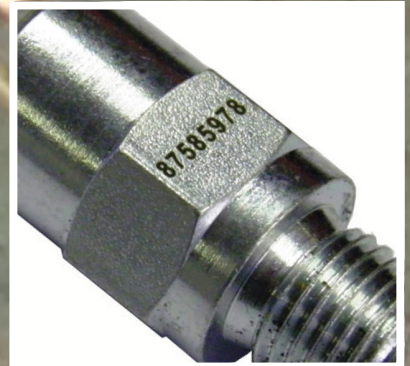
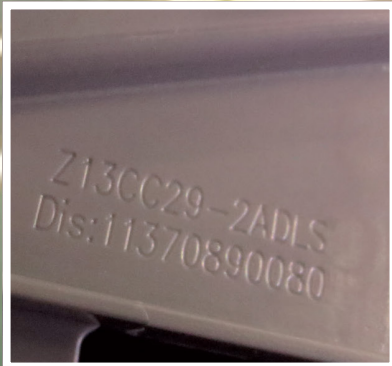

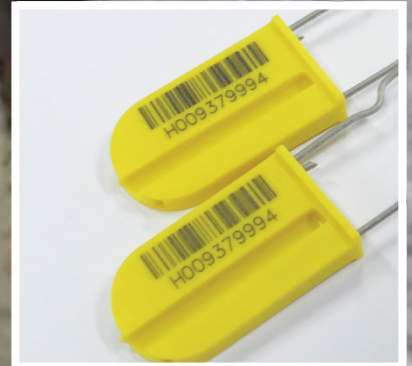
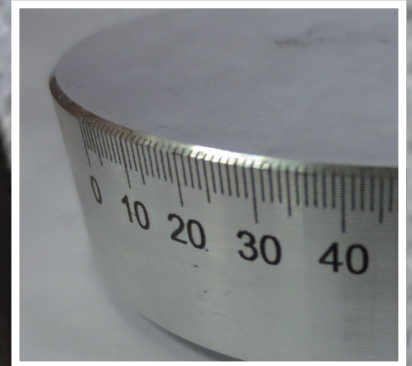
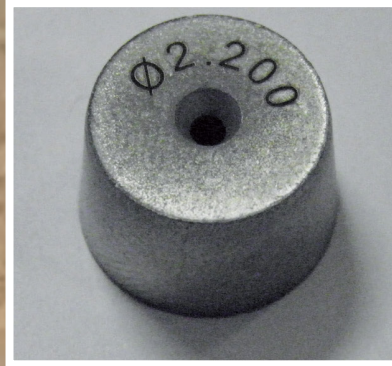
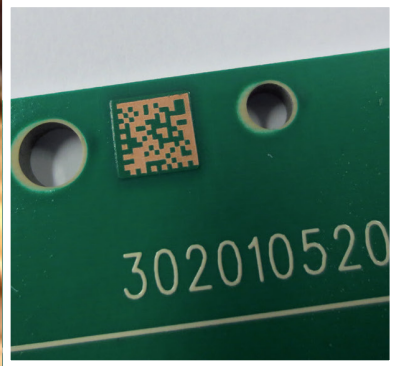

THE BIGGEST MARKING **FAMILY** IN THE WORLD.



AUTOMATOR AMERICA INC - 475 Douglas Ave., Ste. B, Chillicothe, Ohio 45601. USA info.am@automator.com - Ph +1 (740) 983 0157

AUTOMATOR CANADA INC - 2170 Lakeshore Rd. Burlington Ontario, L7R 1A6 CANADA info.ca@automator.com - Ph: +1 (905) 407 8770

www.automator.com